

ITEM NO.	QTY.	PART/DRAWING NO.	DESCRIPTION	MATERIAL
1	1	114-08200-00-2	114 SER. 8.00 X 2.00 PLATED RIGID RIG	STEEL
2	1	08202-44-08	Ø8.00 X 2.00 ET85 TWERGO WHEEL	MISC.
3	1	AX085400	1/2-20 X 3-3/8 SOLID AXLE ZINC	AISI 1038
4	1	LN08200	1/2-20 TOP LOCK NUT	AISI 1038

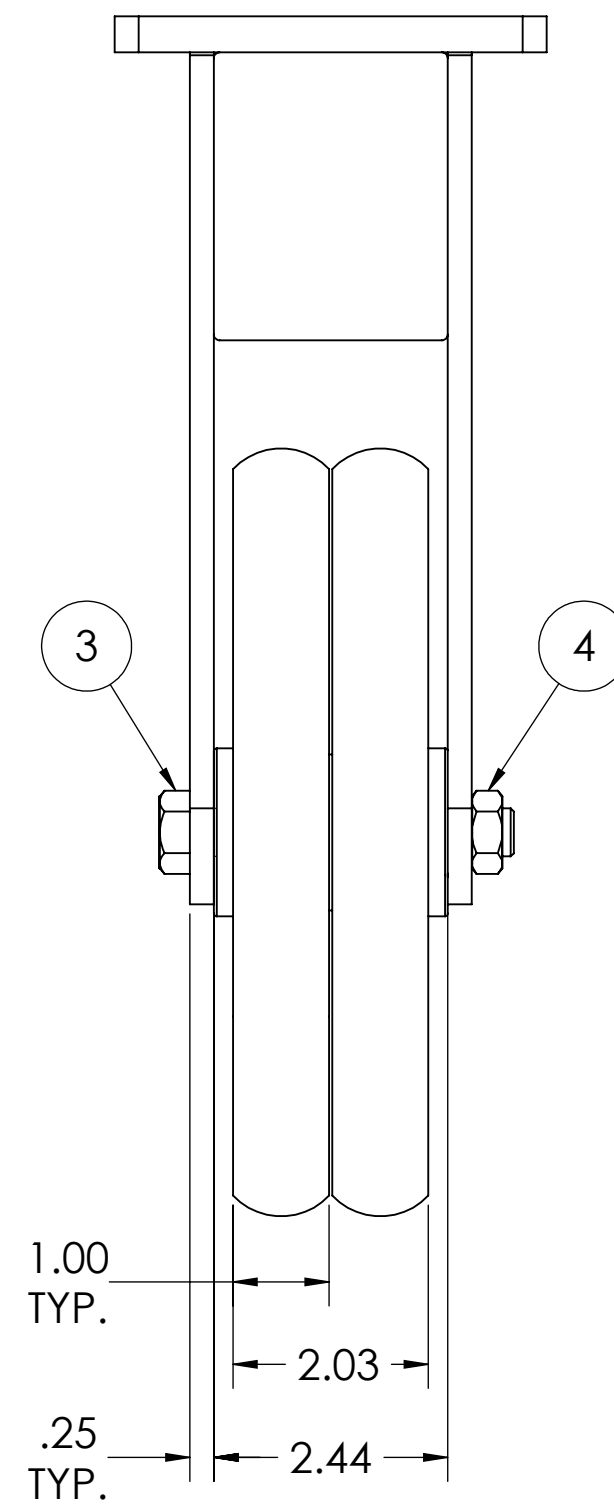
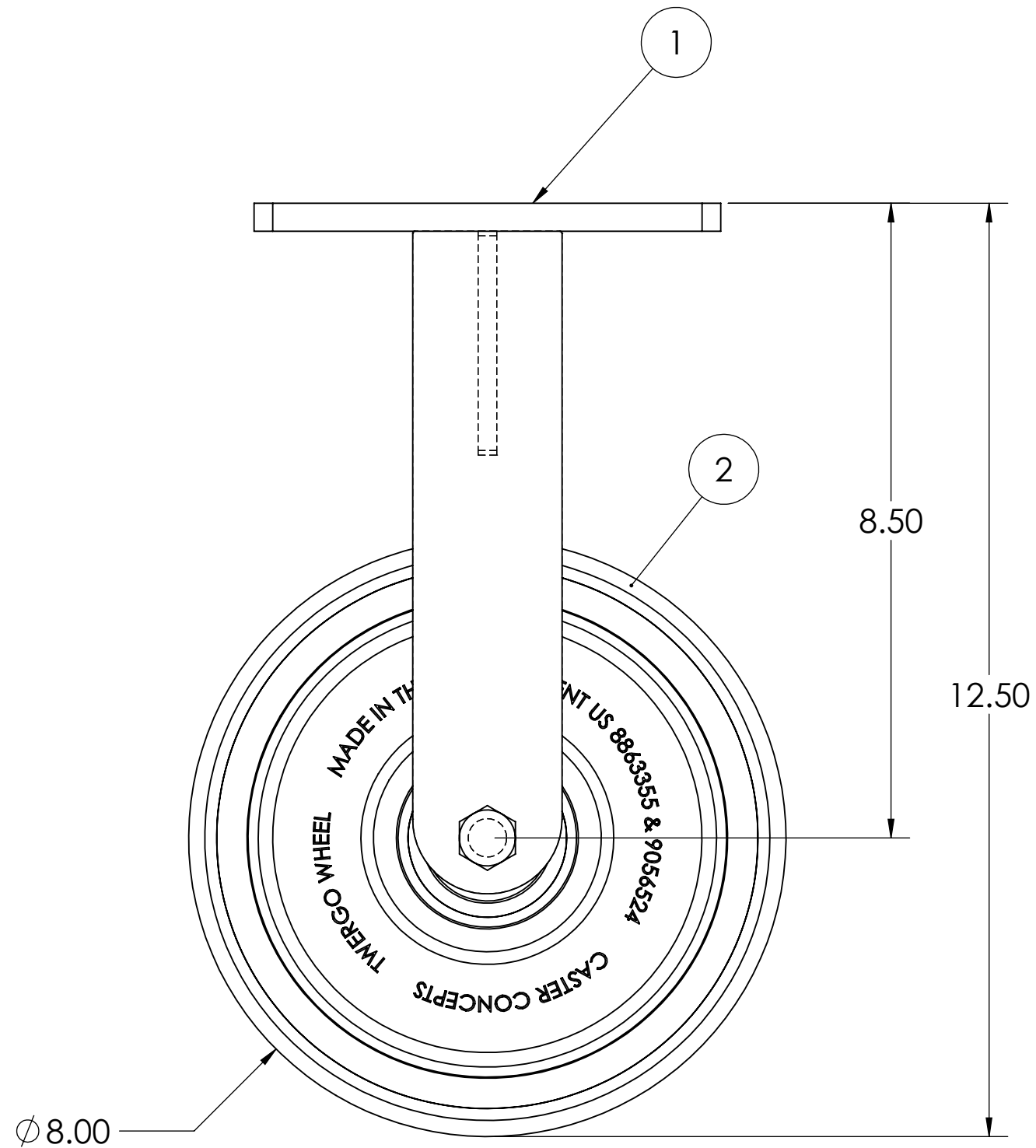
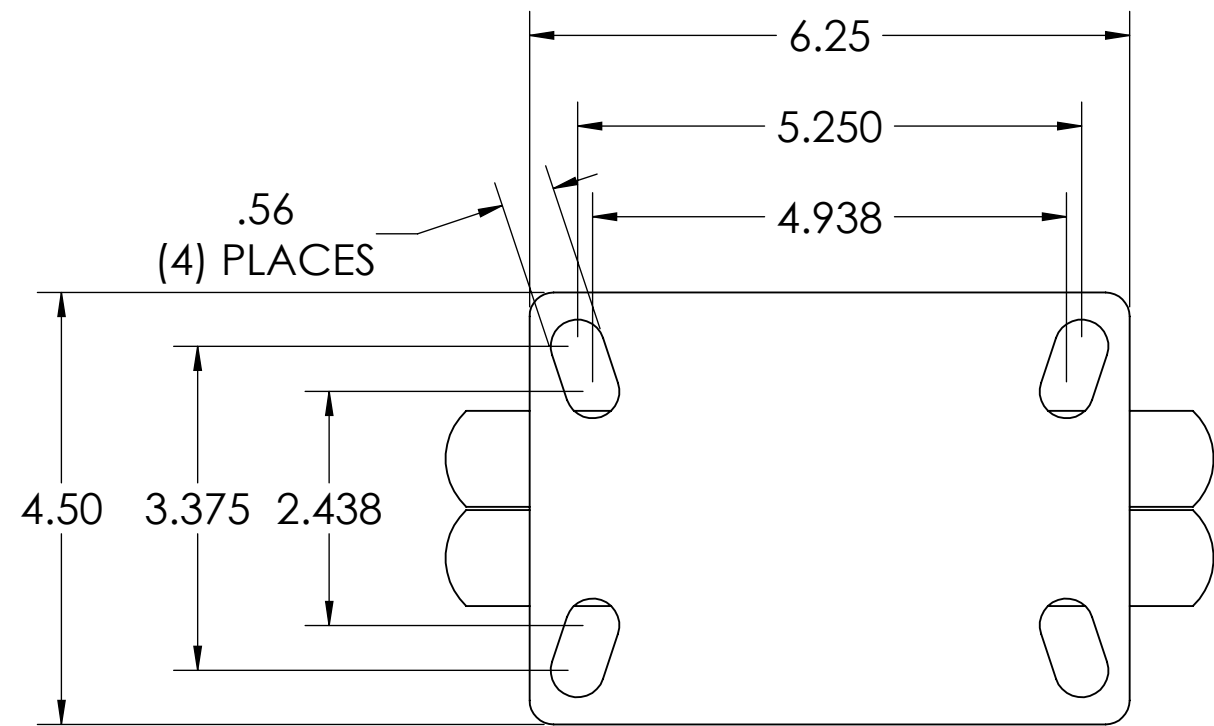
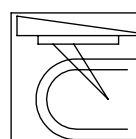

CASTER CONCEPTS, INC.
 16000 E. MICHIGAN AVE.
 ALBION, MI 49224
 (517) 629-8838
 casterconcepts.com

WHERE USED:
 CHECKED BY: ARUN S.

TOLERANCE SPECS. UNLESS OTHERWISE SPECIFIED THE FOLLOWING TOLERANCES APPLY:
 .XX = ±.030 .XXX = ±.010 X° = ±1.0°
 PART TO BE FREE OF BURRS AND SHARP EDGES
FINISH SPECS. ZINC PLATING ON RIG
MATERIAL SPECS.

DESCRIPTION: 114 SER. 8.00 X 2.00 RIGID CASTER
PART/DRAWING NO.: 114-08202-44-2 **DATE:** 6/8/2020
SCALE: 1:2 C-SIZE
APPROVED BY: **DRAWN BY:** SHAGUFTA **THIRD ANGLE**