

**ANSI ICWM:2012
(a revision of ICWM:2004)**



The ICWM Performance Standard for Casters and Wheels

Abstract:

The ICWM Performance Standard for Casters and Wheels provides a common basis for evaluating the safety, durability, structural adequacy, and technical requirements for category specific casters and wheels (Furniture Chair Casters, Furniture Non-Chair Casters, Industrial Casters, Institutional and Medical Equipment Bed Casters). Defines industry terms, specific tests, equipment/methods that can be used, conditions of tests, and minimum acceptance levels used in evaluation. These acceptance levels are based on field and test experiences.

ICWM

Institute of Caster and Wheel Manufacturers

Institute of Casters and Wheel Manufacturers
An Affiliated Trade Association of
Material Handling Industry of America (MHIA),
A Division of Material Handling Industry
8720 Red Oak Blvd., Suite 201
Charlotte, NC, 28217-3992
Telephone: (704) 676-1190
Email: standards@mhia.org
Internet: www.caster.org

© 2012 by Material Handling Industry
All rights reserved.

American National Standard

Approval of an American National Standard requires verification by ANSI that the requirements for due process, consensus, and other criteria for approval have been met by the standards developer.

Consensus is established when, in the judgment of the ANSI Board of Standards Review, substantial agreement has been reached by directly and materially affected interests. Substantial agreement means much more than a simple majority, but not necessarily unanimity. Consensus requires that all views and objections be considered, and that a concerted effort be made toward their resolution.

The use of American National Standards is completely voluntary; their existence does not in any respect preclude anyone, whether he has approved the standards or not, from manufacturing, marketing, purchasing, or using products, processes or procedures not conforming to the standards.

The American National Standards Institute does not develop standards and will in no circumstances give an interpretation of any American National Standard. Moreover, no person shall have the right or authority to issue an interpretation of an American National Standard in the name of the American National Standards Institute. Requests for interpretations should be addressed to the sponsor whose name appears on the title page of this standard.

CAUTION NOTICE: This American National Standard may be revised or withdrawn at any time. The procedures of the American National Standards Institute require that action be taken periodically to reaffirm, revise or withdraw this standard. Purchasers of American National Standards may receive current information on all standards by calling or writing the American National Standards Institute.

Published by

**Institute of Casters and Wheel Manufacturers
An Affiliated Trade Association of
Material Handling Industry of America (MHIA),
A Division of Material Handling Industry
8720 Red Oak Blvd., Suite 201
Charlotte, NC, 28217-3992
Telephone: (704) 676-1190
Email: standards@mhia.org
Internet: www.caster.org**

ANSI ICWM:2012
(a revision of ICWM:2004)

American National Standard

**The ICWM Performance
Standard for Casters and Wheels**

Institute of Caster and Wheel Manufacturers (ICWM)
An Affiliated Trade Association of Material Handling Industry of America (MHIA),
MHIA is a Division of Material Handling Industry

Approved March 29, 2012
American National Standards Institute, Inc.

Disclaimer

FOREWORD. This Standard, which was developed under Material Handling Industry's (MHI) ANSI approved procedures and approved by ANSI on March 29, 2012, represents suggested design practices and operational requirements for Casters and Wheels. It was developed by the Material Handling Industry of America, a division of the Material Handling Industry, (collectively referred to as "MHIA"), along with the ICWM, one of its Affiliated Trade Associations and is intended to provide useful information and guidance for owners, users, designers, purchasers and/or specifiers of material handling equipment or systems. It is advisory only and should only be regarded as a simple tool that its intended audience may or may not choose to follow, adopt, modify, or reject. The following information does not constitute a comprehensive safety program, cannot guard against pitfalls in operating, selecting and purchasing such a system, and should not be relied upon as such. Such a program should be developed, and an independent adviser should be consulted in doing so.

VOLUNTARY. The use of this document is completely voluntary. Its existence does not in any respect preclude anyone, whether it has approved this Standard or not, from following procedures and assuming responsibilities not conforming to this Standard.

DISCLAIMER OF LIABILITY. MHI, MHIA, ICWM and their members assume no responsibility and disclaim all liability of any kind, however arising, as a result of acceptance or use or alleged use of this Standard. Anyone using this Standard specifically understands and agrees that MHI, MHIA, ICWM, their members, officers, agents, and employees shall not be liable under any legal theory of any kind for any action or failure to act with respect to the design, erection, installation, manufacture, and preparation for sale, sale, characteristics, features, or delivery of anything covered by this Standard or any other activity covered by this Standard. Any use of this information must be determined by the user to be in accordance with applicable federal, state, and local laws and regulations.

DISCLAIMER OF WARRANTY. MHI, MHIA, ICWM and their members make **NO WARRANTIES of any kind, express or implied, in connection with the information in this brochure and SPECIFICALLY DISCLAIM ALL IMPLIED WARRANTIES OF MERCHANTABILITY AND OF FITNESS FOR PARTICULAR PURPOSE.**

INDEMNIFICATION. By referring to or otherwise employing this Standard, its user agrees to defend, protect, indemnify, and hold MHI, MHIA, ICWM, their members, officers, agents, and employees harmless from and against all claims, losses, expenses, damages, and liabilities, direct, incidental, or consequential, arising from acceptance or use or alleged use of this Standard, including loss of profits and reasonable attorneys' fees which may arise out of the acceptance or use or alleged use of this document. The intent of this provision is to absolve and protect MHI, MHIA, ICWM their members, officers, agents, and employees from any and all loss relating in any way to this document, including those resulting from the user's own negligence.

FOR Questions Contact:
Material Handling Industry, 8720 Red Oak Blvd., Suite 201, Charlotte, NC 28217-3992;
standards@mhia.org.

Foreword (This foreword is not part of American National Standard ICWM)

In 1996, the Institute of Caster and Wheel Manufacturers (ICWM) Long Range Planning Committee identified the need to develop a complete and comprehensive North American performance standard for casters and wheels.

Until this project was undertaken by the newly appointed ICWM Standards Committee (September, 1996), a comprehensive North American performance standard for casters and wheels did not exist. The ICWM Standards Committee, consisting of a cross section of the top engineers in the caster and wheel industry, met on an almost monthly basis for three and a half years to complete the work of producing the ICWM North American Performance Standard for Casters and Wheels.

The Institute of Caster and Wheel Manufacturers is an evolutionary refinement of the Caster & Floor Truck Manufacturers Association, which was founded in 1933 to educate members and users about the products of this industry and to maintain liaison with governmental agencies and other organizations. In 1950 the Association began developing standards for manual material handling products. Through the years, the Association and the Institute have developed a series of caster and wheel standards and standards for industrial trailer trucks, platform trucks, and towline trucks. ICWM cooperated with the General Service Administration, the Department of Defense, Post Office and other agencies in establishing federal and military specifications. In 1967 ICWM developed the American National Standards Institute's Industrial Caster Standard MH11.1.

At the date of approval of the 2012 revision of this standard, the Institute of Caster and Wheel Manufacturers (ICWM) consisted of the following member companies:

Albion Industries
Colson Caster Corporation
E.R. Wagner Mfg. Co. – Casters & Wheels
Hamilton Caster & Mfg. Co.
Jarvis Caster Company
RWM Casters
Shepherd Caster Corporation
Superior Tire & Rubber Corp.

Suggestions for improvement, and questions regarding interpretation of this standard will be welcome. They should be sent to: ICWM Standard Committee, c/o Material Handling Industry of America, 8720 Red Oak Blvd., Suite 201, Charlotte, NC, 28217-3992 or standards@mhia.org.

The ICWM Performance Standard for Casters and Wheels

Table of Contents

1	INTRODUCTION AND SCOPE	1
2	TERMS, DEFINITIONS, SYMBOLS AND DIMENSIONS	2
2.1	Definitions Relating to Wheels and Constituent Parts.....	2
2.1.1	Wheel	2
2.1.2	Hub.....	2
2.1.3	Rim	2
2.1.4	Web	2
2.1.5	Core.....	3
2.1.6	Tire	3
2.1.7	Tread	4
2.1.8	Wheel Bearing.....	4
2.2	Definitions Related to Wheel Construction.....	4
2.2.1	Solid Wheel (bare wheel)	4
2.2.2	Composite Wheel.....	4
2.2.3	Flange Wheel	5
2.2.4	Single-Flanged Rail Wheel.....	6
2.2.5	Grooved Wheel.....	6
2.2.6	Electric Conductive Wheel	6
2.2.7	Flame Retardant Wheel	6
2.2.8	Load Wheel	6
2.2.9	Stabilizer Wheel.....	7
2.2.10	Guide Wheel.....	7
2.3	Dimensional Characteristics of the Wheel.....	7
2.3.1	Diameter	7
2.3.2	Wheel Hub Diameter	7
2.3.3	Bore Diameter	8
2.3.4	Bearing Seat Diameter.....	8
2.3.5	Wheel Width	8
2.4	Definitions Relating to Axle and Mountings.....	10
2.4.1	Axle.....	10
2.4.2	Fork Mounting.....	10
2.4.3	Stub-Axle Mounting.....	10
2.4.4	Dual Wheel Stub-Axle Mounting	10

2.5	Definitions Relating to Casters	11
2.5.1	Caster	11
2.5.2	Rigid Caster	11
2.5.3	Swivel Caster	11
2.5.4	Dual-Wheel Caster.....	12
2.5.5	Inclined Axle Caster.....	12
2.5.6	Housing/Rig.....	12
2.5.7	Fork	13
2.5.8	Mounting Plane.....	13
2.5.9	Top Plate.....	13
2.5.10	Stem	13
2.5.11	Hollow Kingpin.....	14
2.5.12	Swivel Axis	14
2.5.13	Swivel Bearing.....	14
2.6	Definitions for Caster	14
2.6.1	Threadguard	14
2.6.2	Braking and/or Locking Devices	15
2.6.3	Shock-Absorbing Caster	17
2.6.4	Steering Attachment	17
2.6.5	Foot Guard	18
2.6.6	Wheel Hood.....	18
2.6.7	Dual-Wheel Caster with a Pivoting Axle.....	18
2.7	Dimensional Characteristics of the Caster	19
2.7.1	Overall Height.....	19
2.7.2	Offset	19
2.7.3	Swivel Radius	20
2.7.4	Fork Width.....	21
2.7.5	Outer Dimensions	21
2.7.6	Attaching Bolt Diameter	21
2.7.7	Bolt-Hole Spacing.....	21
2.7.8	Stem Diameter.....	22
2.7.9	Stem Length	22
2.7.10	Hollow Kingpin Mounting.....	23
2.8	Load Capacity	23
2.9	Weight	23
2.10	Forces	24
2.10.1	Start-rolling force.....	24
2.10.2	Keep-rolling force	24
2.10.3	Swivel force.....	24

- 3 **REFERENCED STANDARDS** 25
- 4 **TEST APPARATUS AND CONDITIONS**..... 26
 - 4.1 Sequence of Tests for All Casters 26
 - 4.2 Wheel Play Test 26
 - 4.3 Swivel Play Test 27
 - 4.4 Rollability Test..... 28
 - 4.5 ConductivityTest..... 28
 - 4.6 Wheel Brake and Swivel Lock Efficiency Test 29
 - 4.7 Braking and/or Locking Fatigue Test 29
 - 4.8 Dynamic Test 30
 - 4.9 Static Test 31
 - 4.10 Side Load Test 31
 - 4.11 Caster/Wheel - Vertical Impact Test 32
- 5 **FURNITURE CASTERS**..... 34
 - 5.1 Categories 34
 - 5.2 Dimensions 34
 - 5.3 Testing - General Requirements..... 34
 - 5.4 Test Procedures and Acceptance Criteria..... 34
 - 5.4.1 Test Procedure 34
 - 5.4.2 Vertical Impact Test 36
 - 5.4.3 Caster Retention..... 37
 - 5.4.4 Conductivity Test..... 37
 - 5.5 Conformity 38
- 6 **INDUSTRIAL CASTERS** 39
 - 6.1 Wheel Play Test 39
 - 6.1.1 Test Procedure 39
 - 6.1.2 Acceptance Criteria 39
 - 6.2 Swivel Play Test 39
 - 6.2.1 Test Procedure 39
 - 6.2.2 Acceptance Criteria 40
 - 6.3 Rollability Test 40
 - 6.3.1 Test Procedure 40
 - 6.3.2 Acceptance Criteria 41
 - 6.4 Conductivity Test 41
 - 6.4.1 Test Procedure 41
 - 6.4.2 Acceptance Criteria 42
 - 6.4.3 Disclaimer 42
 - 6.5 Wheel Brake Efficiency Test 42
 - 6.5.1 Test Procedure 42
 - 6.5.2 Acceptance Criteria 43
 - 6.6 Braking and/or Locking Device Fatigue Test 43

6.6.1	Test Procedure	43
6.6.2	Acceptance Criteria	43
6.7	Static Test	43
6.7.1	Test Procedure	43
6.7.2	Acceptance Criteria	43
6.8	Dynamic Test	44
6.8.1	Dynamic Test - Industrial Casters at or under 2.5 mph	44
6.8.1.1	Test Procedure.....	44
6.8.1.2	Acceptance Criteria	44
6.8.2	Dynamic Test - Industrial Casters over 2.5 mph.....	45
6.8.2.1	Test Procedure.....	45
6.8.2.2	Acceptance Criteria	45
6.9	Side Load Test	46
6.9.1	Test Procedure	46
6.9.2	Acceptance Criteria	46
6.10	Casters - Vertical Impact Test	46
6.10.1	Test Procedure	46
6.10.2	Acceptance Criteria	46
6.11	Wheels - Vertical Impact Test.....	47
6.11.1	Test Procedure	47
6.11.2	Acceptance Criteria	47
7	INSTITUTIONAL AND HOSPITAL BED CASTERS.....	48
7.1	Wheel Play Test	48
7.1.1	Test Procedure	48
7.1.2	Acceptance Criteria	48
7.2	Swivel Play Test	48
7.2.1	Test Procedure	48
7.2.2	Acceptance Criteria	49
7.3	Rollability Test	49
7.3.1	Test Procedure	50
7.3.2	Acceptance Criteria	50
7.4	Wheel Brake Efficiency Test	50
7.4.1	Test Procedure	50
7.4.2	Acceptance Criteria	51
7.5	Swivel Lock Efficiency Test	51
7.5.1	Test Procedure	51
7.5.2	Acceptance Criteria	52
7.6	Braking and/or Locking Device Fatigue Test	52
7.6.1	Test Procedure	52
7.6.2	Acceptance Criteria	52
7.7	Static Test	52
7.7.1	Test Procedure	52
7.7.2	Acceptance Criteria	52
7.8	Dynamic Test	52

7.8.1	Test Procedure	52
7.8.2	Acceptance Criteria	53
7.9	Conductivity Test	53
7.9.1	Test Procedure	53
7.9.2	Acceptance Criteria	54
7.9.3	Disclaimer	54
7.10	Castors - Vertical Impact Test	54
7.10.1	Test Procedure	54
7.10.2	Acceptance Criteria	54
7.11	Wheels - Vertical Impact Test.....	54
7.11.1	Test Procedure	55
7.11.2	Acceptance Criteria	55

The ICWM Performance Standard for Casters and Wheels

1 INTRODUCTION AND SCOPE

This standard is intended to provide manufacturers, specifiers and users with a common basis for evaluating the safety, durability, structural adequacy, and technical requirements for group specific casters and wheels. The standard defines industry terms, specific tests, equipment/methods that can be used, the conditions of tests, and minimum acceptance levels to be used in evaluating these products. These acceptance levels are based on field and test experience of the Institute of Caster and Wheel Manufacturer (ICWM) members.

The ICWM Standard for Casters and Wheels addresses the total range or market for casters and wheels for these three categories:

1. Furniture Chair Casters
2. Industrial Casters (at or under 2.5 mph and over 2.5 mph)
3. Institutional and Medical Equipment Casters

The ICWM Standards Committee has also prepared a complete glossary of caster and wheel terms, definitions, symbols and dimensions. Additionally, appropriate caster and wheel test equipment, procedures and methods are delineated and incorporated into this standard.

2 TERMS, DEFINITIONS, SYMBOLS AND DIMENSIONS

This section covers terms, definitions, symbols and dimensions relating to casters and wheels.

2.1 Definitions Relating to Wheels and Constituent Parts

2.1.1 Wheel

Circular structure able to rotate on an axle (2.4.1), either directly or with the use of bearing(s) (2.1.8). The external part of the structure is in contact with the ground.



Figure 1: Wheel

2.1.2 Hub

Central part of the wheel (2.1.1) to receive the axle (2.4.1) or wheel bearing(s) (2.1.8).



Figure 2: Hub

2.1.3 Rim

The outer profile of a core (2.1.5), connected to the hub (2.1.2) by a web (2.1.4).



Figure 3: Rim

2.1.4 Web

Part of the wheel (2.1.1) between the hub (2.1.2) and the rim (2.1.3).



Figure 4: Web

2.1.5 Core

Part of the wheel (2.1.1) comprising the hub (2.1.2), web (2.1.4) and the rim (2.1.3) suitable to receive a tire (2.1.6).



Figure 5: Core

2.1.5.1 Solid Core

Core (2.1.5) made from only one material.

2.1.5.2 Composite Core

Core (2.1.5) made from assembled parts.

2.1.6 Tire

Outer part of a wheel (2.1.1), the material of which can be different from the core (2.1.5). The tire can be fixed or de-mountable.

2.1.6.1 Solid Tire

Tire (2.1.6) not containing air.

2.1.6.2 Semi-Pneumatic Tire

Tire (2.1.6) with cavity containing air to zero pressure.

2.1.6.3 Foam Tire

Tire (2.1.6) having an open or closed cellular structure.

2.1.6.4 Pneumatic Tire

Tire (2.1.6) suitable to contain air at a pressure, which can be adjusted.

2.1.7 Tread

Outer surface of a wheel (2.1.1) or a tire (2.1.6), in contact with the ground.



Figure 6: Tread

2.1.8 Wheel Bearing

Device(s) intended to ease the rotation of a wheel (2.1.1) around its axle (2.4.1); for example, sleeve and self-lubricated bearings, ball bearings, roller bearings, etc.

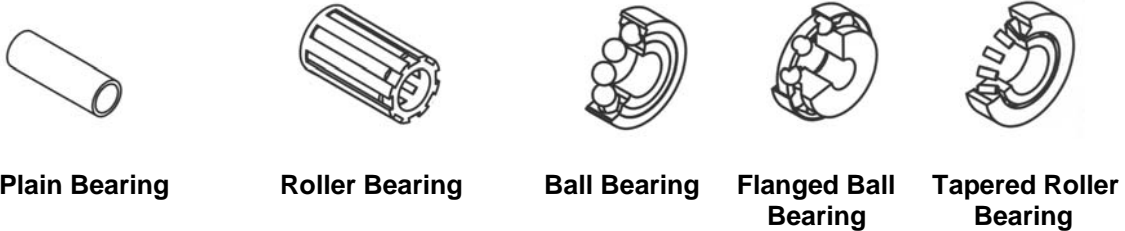

Plain Bearing

Roller Bearing

Ball Bearing

Flanged Ball Bearing

Tapered Roller Bearing

Figure 7: Bearings

2.2 Definitions Related to Wheel Construction

The following are examples of the most frequently used wheels per 2.1.

2.2.1 Solid Wheel (bare wheel)

Wheel (2.1.1) made of metal, plastic, rubber, polyurethane or other materials that is used without any added tire (2.1.6).

2.2.2 Composite Wheel

Wheel (2.1.1) comprised of a core (2.1.5) and a tire (2.1.6).



Figure 8: Composite Wheel

2.2.2.1 Bonded/Mold-on Tire Wheel

Wheel (2.1.1) with a tire (2.1.6) permanently fixed to the rim (2.1.3).



Figure 9: Bonded/Mold-on (Permanently Tired) Tire Wheel

2.2.2.2 De-mountable Tire Wheel

Wheel (2.1.1) with a tire (2.1.6) that is detachable.



Figure 10: De-mountable Tire Wheel

2.2.2.3 Press-on Tire Wheel

Wheel (2.1.1) comprised of a core (2.1.5) with a tire (2.1.6) that is pressed on.

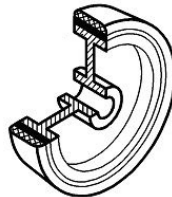

Figure 11: Press-on Tire Wheel

2.2.3 Flange Wheel

Wheel (2.1.1) with a connecting web (2.1.4) suitable for fitting to a hub (2.1.2) or stub axle.



Figure 12: Flange Wheel

2.2.4 Single-Flanged Rail Wheel

Wheel (2.1.1) designed to run on a rail or guiding track.



Figure 13: Single-Flanged Rail Wheel

2.2.5 Grooved Wheel

Wheel (2.1.1) designed to run on various rail profiles or used with ropes or cables.



Figure 14: Grooved Wheel

2.2.6 Electric Conductive Wheel

Wheel (2.1.1) with controlled electrical resistance, used to dissipate static electricity.

2.2.7 Flame Retardant Wheel

Wheel (2.1.1) with its components made of flame retardant materials that must meet the requirements UL94, V-1.

2.2.8 Load Wheel

Wheel (2.1.1), which bears the dynamic and static pressures of the vehicle to which it is fitted.

2.2.8.1 Drive Wheel

Load wheel connected directly or through a clutch, to the power system, which provides the torque necessary for transmission of motion.

2.2.8.2 Steer Wheel

Free running wheel (2.1.1), connected to a steering device, which controls the running direction of the vehicle to which it is fitted.

2.2.8.3 Drive Steer Wheel

Load wheel connected to the power system(s) and to a steering device, which performs the duties as in 2.2.8.1 and 2.2.8.2 simultaneously.

2.2.9 Stabilizer Wheel

Wheel (2.1.1) solidly or resiliently mounted on a chassis of a vehicle; used to assist in maintaining stability.

2.2.10 Guide Wheel

Wheel (2.1.1) to control the movement of the vehicle along a pre-determined path.

2.3 Dimensional Characteristics of the Wheel

2.3.1 Diameter (D)

Outer nominal diameter of the wheel (2.1.1).

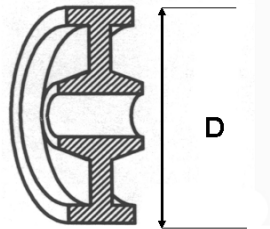

Figure 15: Diameter

2.3.2 Wheel Hub Diameter (M)

Smallest diameter of the hub (2.1.2).

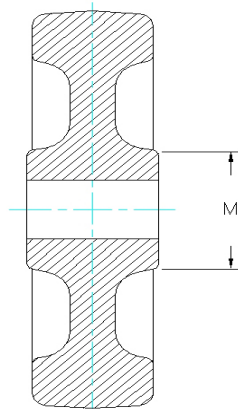

Figure 17

Figure 16: Hub Diameter

2.3.3 Bore Diameter (d)

Nominal diameter (d) of the hole through the hub (2.1.2), or nominal diameter of the bearing(s) (2.1.8) to receive the axle (2.4.1).

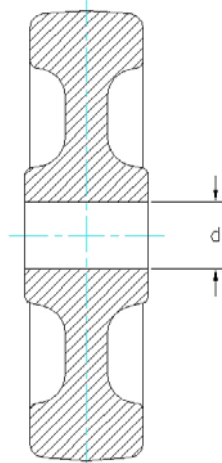

Figure 18

Figure 17: Bore Diameter

2.3.4 Bearing Seat Dimensions (s x t)

Nominal diameter and depth of the seat to receive the bearing(s) (2.1.8).

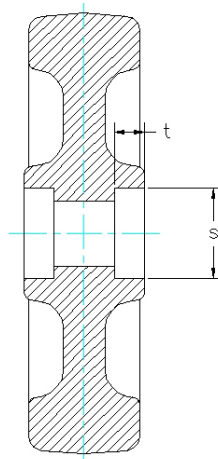

Figure 19

Figure 18: Bearing Seat Dimensions

2.3.5 Wheel Width

Widest part of the wheel (2.1.1), either the hub width T1 (2.3.5.1), or tread width T2 (2.3.5.2).

2.3.5.1 Hub Width (T1)

Widest part of the hub (2.1.2), including bearing assembly (2.1.8) and threadguards (2.6.1), if fitted.

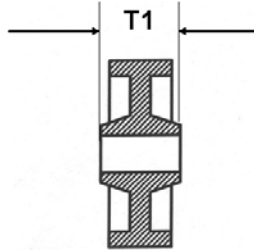

Figure 19: Hub Width

2.3.5.2 Tread Width (T2)

Width of the tire (2.1.6) measured at the widest point and parallel to the revolving axis.

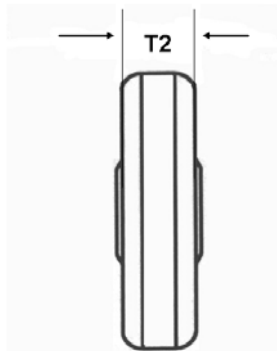

Figure 20: Tread Width

2.3.5.3 Contact Area (T3)

Area of the tread in contact with the surface (2.1.7).

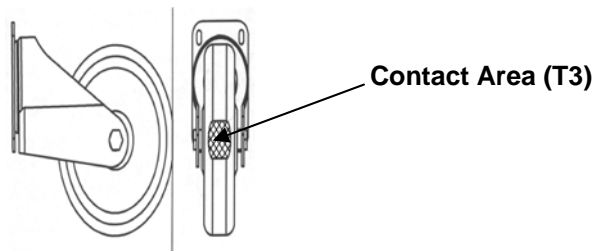

Figure 21: Contact Area

2.3.5.4 Tire Profile

The shape of the tire or tread on its outer diameter (2.3.1) usually flat, round or crowned.

2.4 Definitions Relating to Axle and Mountings

2.4.1 Axle

A circular sectional part on which the wheel may revolve either directly or with the use of anti-friction bearings.

2.4.2 Fork Mounting

Assembly where the axle (2.4.1) is supported on both sides of the hub (2.1.2).

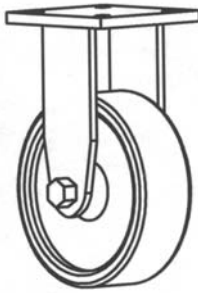

Figure 22: Fork Mounting

2.4.3 Stub-Axle Mounting

Assembly to support the axle (2.4.1) only on one side of the hub (2.1.2).

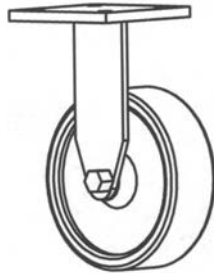

Figure 23: Stub-Axle Mounting

2.4.4 Dual Wheel Stub-Axle Mounting

Assembly to support the axle (2.4.1) only between the wheels (2.1.1).

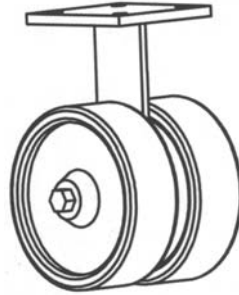

Figure 24: Dual Wheel Stub-Axle Mounting

2.5 Definitions Relating to Casters

2.5.1 Caster

Assembly comprising a housing/rig (2.5.6), one or more wheels (2.1.1), an axle (2.4.1) and, if required, accessories (2.6).

2.5.2 Rigid Caster

Assembly including one or more wheels (2.1.1) in a rigid housing/rig (2.5.6).



Figure 25: Rigid Caster

2.5.3 Swivel Caster

Assembly including one or more wheels (2.1.1) in a housing/rig (2.5.6), which rotates freely around a vertical axis. The axis of the wheel(s) (2.1.1) is normally offset (2.7.2) to the swivel axis (2.5.12) of the fork (2.5.7) as shown in Figure 46.



Figure 26: Swivel Caster

2.5.4 Dual-Wheel Caster

Swivel or rigid assembly including two wheels (2.1.1), which rotate independently.

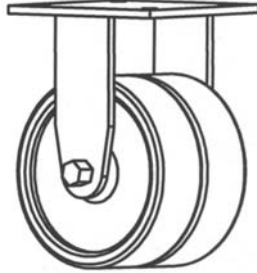

Figure 27: Dual-Wheel Caster

2.5.5 Inclined Axle Caster

Assembly in a swivel housing/rig (2.5.6) which rotates freely around its vertical axis. The axis of the wheel, which is inclined to the ground, is offset to the swivel axis (2.5.12).



Figure 28: Inclined Axle Caster

2.5.6 Housing/Rig

Swivel or rigid assembly, designed to be connected to mobile equipment.

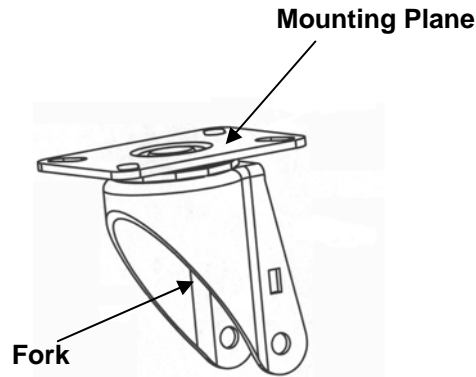

Figure 29: Housing/Rig

2.5.7 Fork

Supporting structure with one or more legs designed to accommodate an axle (2.4.1) and wheel(s) (2.1.1).

2.5.8 Mounting Plane

Surface of the caster (2.5.1) or housing/rig (2.5.6) to be connected to mobile equipment.

2.5.9 Top Plate

Upper part of a housing/rig (2.5.6), with or without holes or slots for connection to the equipment.

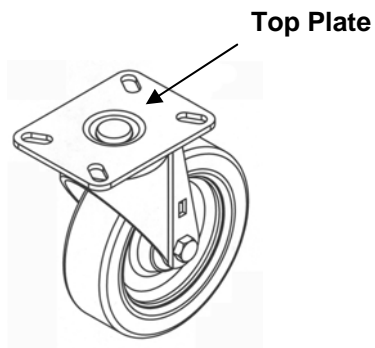

Figure 30: Top Plate

2.5.10 Stem

Vertical upper part of a housing/rig (2.5.6) to fit into a socket, threaded boss, or other receptacle in mobile equipment.

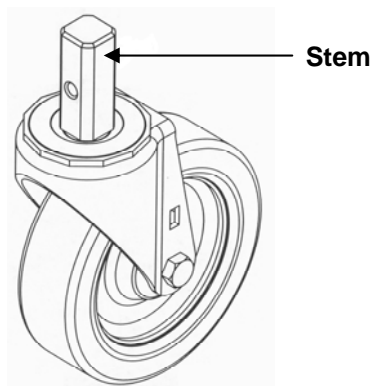

Figure 31: Stem

2.5.11 Hollow Kingpin

Through-hole on the upper side of the housing/rig (2.5.6) suitable for the connection to mobile equipment.

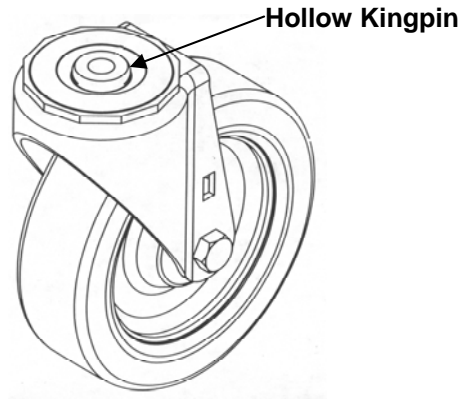

Figure 32: Hollow Kingpin

2.5.12 Swivel Axis

Vertical axis around which the fork (2.5.7) rotates.

2.5.13 Swivel Bearing

Device that allows the free rotation of the fork (2.5.7) around its swivel axis (2.5.12).

2.6 Definitions for Caster

2.6.1 Threadguard

Circular shielding components, assembled on the sides of a wheel (2.1.1) to protect the hub (2.1.2) from threads and other foreign objects, which may prevent free rotation of the wheel (2.1.1).

2.6.2 Braking and/or Locking Devices

Devices to prevent the rotation of the housing/rig (2.5.6) around the swivel axis (2.5.12), or the rotation of the wheel(s) (2.1.1) or both.

2.6.2.1 Wheel Braking and/or Locking Device

Device to prevent the wheel(s) (2.1.1) from rotating, leaving the housing/rig (2.5.6) free to swivel. This device is to be used only as a parking brake.

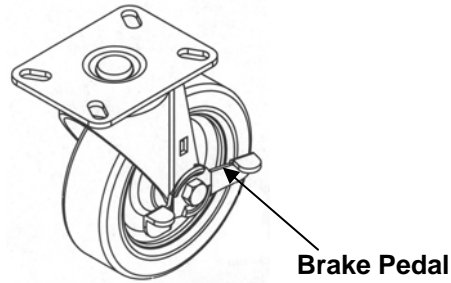

Figure 33: Wheel Braking and/or Locking Device

2.6.2.2 Dynamic Brake

Device to be used to slow down or stop wheel(s) (2.1.1) in motion. This device can also be used as a parking brake. Note that this standard does not include specifications for dynamic brakes.

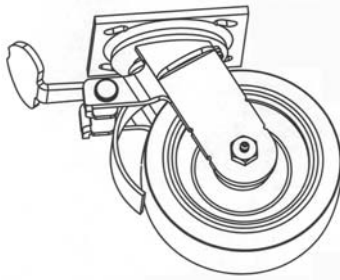

Figure 34: Dynamic Brake

2.6.2.3 Central Braking and/or Locking Device

Device within the caster (2.5.1), to operate through the swivel axis (2.5.12) that prevents either the rotation of the swivel housing/rig (2.5.6), the wheel(s) (2.1.1) or both. This device is to be used only as a parking brake.

2.6.2.4 Total Braking and/or Locking Device

Device to simultaneously prevent the rotation of the wheel(s) (2.1.1) and the swivel housing/rig (2.5.6). This device is to be used only as a parking brake.

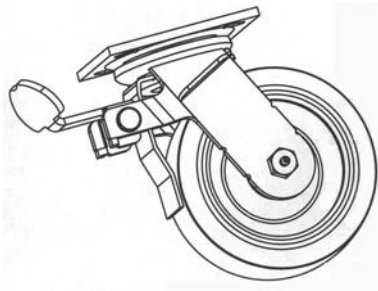

Figure 35: Total Braking and/or Locking Device

2.6.2.5 Directional Locking Device

Device to prevent the rotation of the fork (2.5.7) of a swivel caster (2.5.3) in one or more predetermined positions. This device can be used to convert a swivel caster (2.5.3) to a rigid caster (2.5.2).

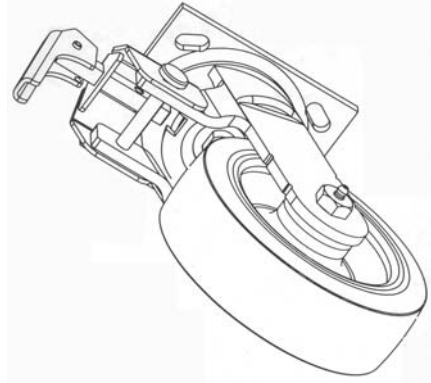

Figure 36: Directional Locking Device

2.6.2.6 Braking Device for Office Chairs

Device to prevent the wheel(s) (2.1.1) from rotating when the chair is unloaded.



Figure 37: Braking Device for Office Chairs

2.6.2.7 Central Braking and/or Locking Device for Hospital Beds

Device to control the caster (2.5.1) by means of a mechanism through the stem (2.5.10), allowing three alternative functions: total braking/locking as in 2.6.2.4, directional locking as in 2.6.2.5, or no braking/locking action of the housing/rig (2.5.6) or wheel(s).

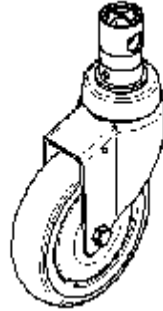

Figure 38: Central Braking and/or Locking Device for Medical Equipment

2.6.3 Shock-Absorbing Caster

Caster (2.5.1) specifically designed to absorb shocks and impacts.

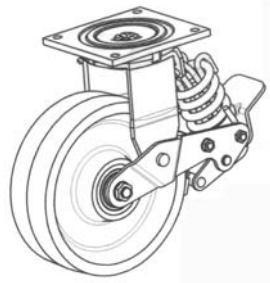

Figure 39: Shock-Absorbing Caster

2.6.4 Controlling the Steering Attachment

Device for controlling the rotation of the housing/rig (2.5.6).

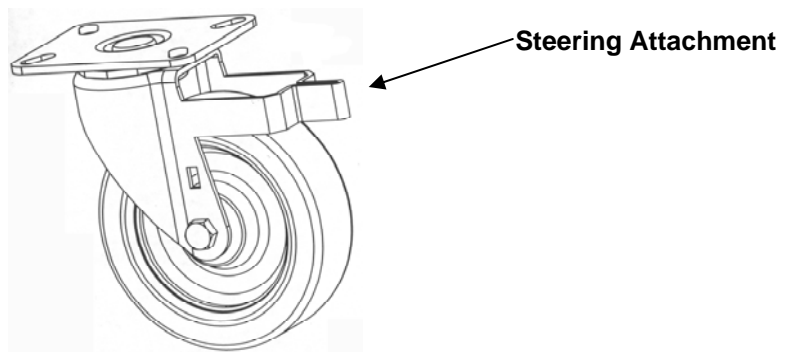

Figure 40: Steering Attachment

2.6.5 Foot Guard

Device, integral with the fork (2.5.7) to minimize interference between a wheel and other objects.

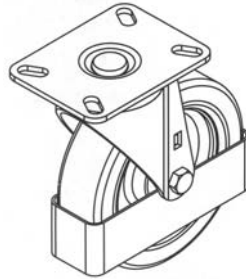

Figure 41: Foot Guard

2.6.6 Wheel Hood

Device to cover the wheel (2.1.1).

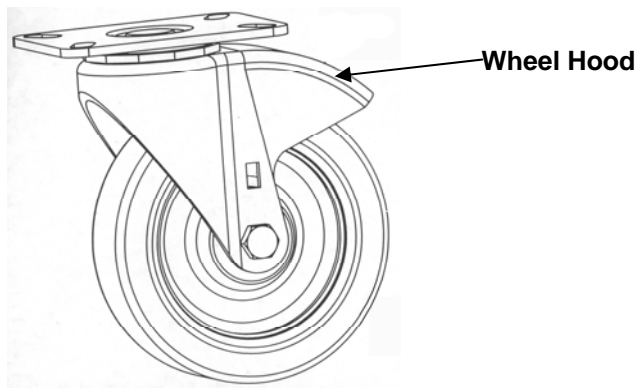

Figure 42: Wheel Hood

2.6.7 Dual-Wheel Caster with a Pivoting Axle

Caster (2.5.1) with dual wheel(s) (2.1.1) on a stub-axle mounting (2.4.3) with a central fulcrum.

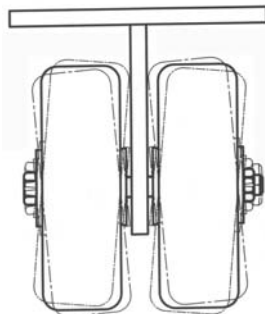

Figure 43: Dual-Wheel Caster with a Pivoting Axle

2.7 Dimensional Characteristics of the Caster

2.7.1 Overall Height

Distance measured vertically between the ground and mounting plane (2.5.8) of a caster.

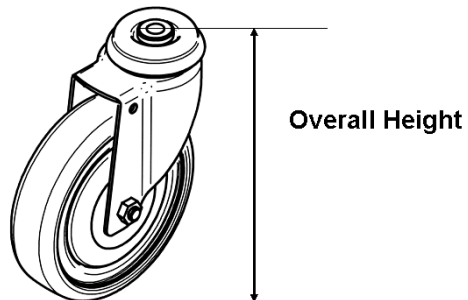

Figure 44: Overall Height

2.7.2 Offset

Distance measured horizontally between the vertical swivel (swivel lead) axis (2.5.12) of the caster (2.5.1) and the axis of the wheel(s) (2.1.1).

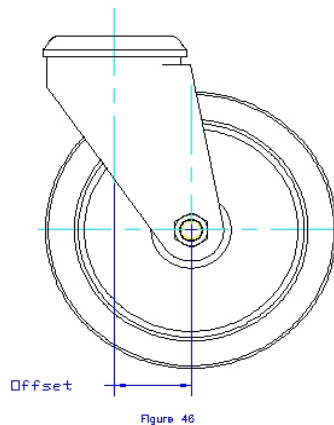

Figure 45: Offset

2.7.3 Swivel Radius

Distance measured horizontally, between the vertical swivel axis (2.5.12) and the most protruding point of the caster (2.5.1) or its accessories. This radius defines the minimum circle in which the caster is free to rotate through 360°.

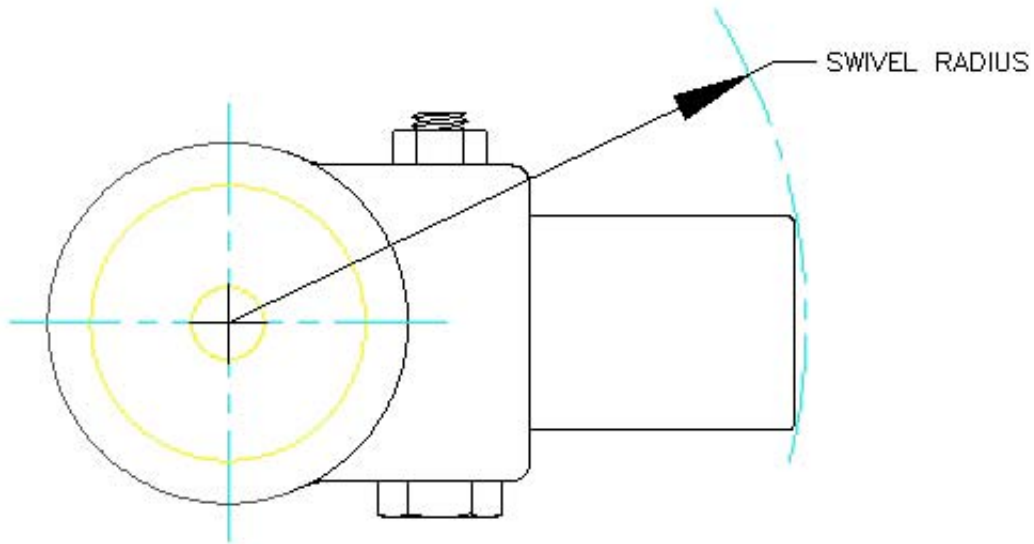

Figure 47

Figure 46: Swivel Radius

2.7.4 Fork Width (*leg spacing*)

Distance between the inner surfaces of the legs of the fork (2.5.7), measured along the axis of the wheel(s) (2.1.1).

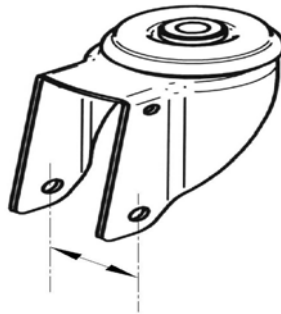

Figure 47: Fork Width

2.7.5 Outer Dimensions (A x B or C x D)

Dimensions of the top plate (2.5.9).

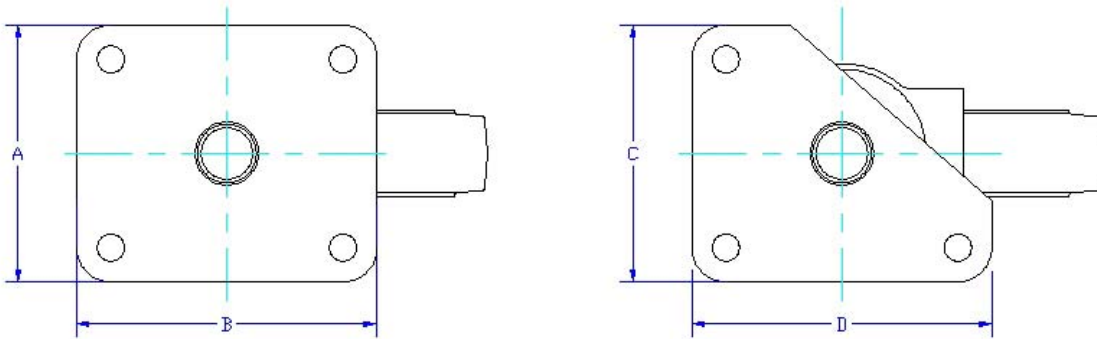

FIGURE 48

Figure 48: Top Plate Outer Dimensions

2.7.6 Attaching Bolt Diameter

Diameter of the attaching bolts to connect the caster to the equipment through the round or slotted holes in the top plate (2.5.9).

2.7.7 Bolt-Hole Spacing (E x F or K x L)

Distance between the axes of the top plate (2.5.9) bolt holes.

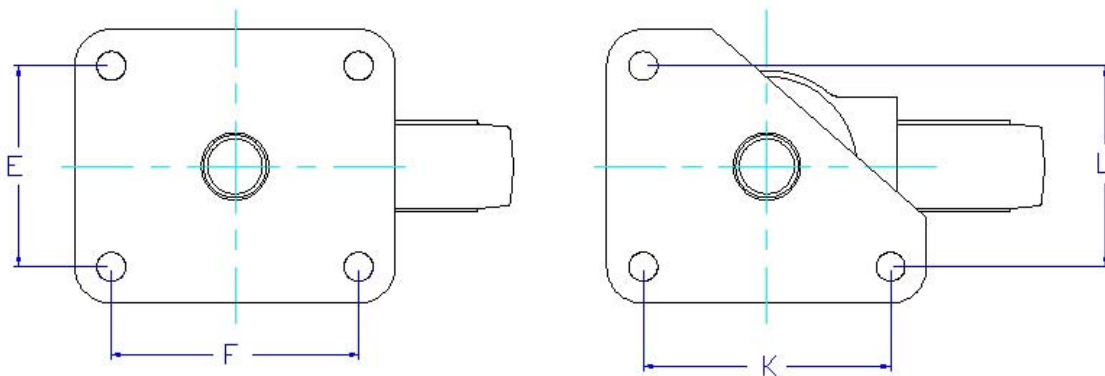

FIGURE 49

Figure 49: Bolt-Hole Spacing

2.7.8 Stem Diameter

Diameter of the stem (2.5.10).

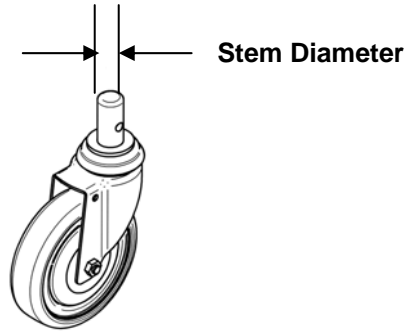

Figure 50: Stem Diameter

2.7.9 Stem Length

Length of the stem (2.5.10) above the mounting plane (2.5.8).

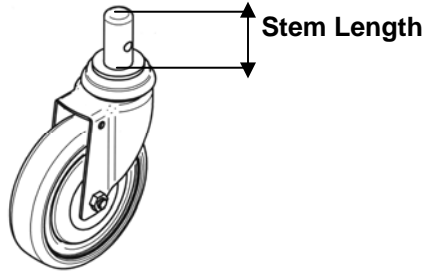

Figure 51: Stem Length

2.7.10 Hollow Kingpin Mounting

Diameter of the bolt used to connect the caster (2.5.1) to the equipment through a hollow kingpin (2.5.11).

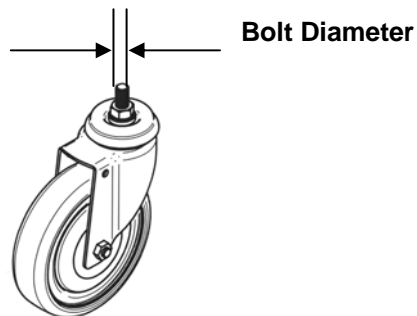

Figure 52: Hollow Kingpin Mounting

2.8 Load Capacity

Maximum rated load in pounds or kilograms, which can be carried by a wheel (2.1.1) or a caster (2.5.1).

Load Capacity



Figure 53: Load Capacity

2.9 Weight

Weight of the wheel (2.1.1) or caster (2.5.1), in pounds or kilograms.



Weight of Caster

Figure 54: Weight

2.10 Forces

2.10.1 Start-rolling force

Force required to cause forward rotation of the caster wheel.

2.10.2 Keep-rolling force

Force required to maintain forward caster wheel rotation after initial rotation.

2.10.3 Swivel force

Force required to swivel the caster 90°.

3 REFERENCED STANDARDS

The following standards are referenced throughout this standard:

BIFMA X5.1 - 2002

BS EN 12526:1999

BS EN 12527:1999

BS EN 12528:1999

BS EN 12529:1999

BS EN 12530:1999

BS EN 12531:1999

BS EN 12532:1999

BS EN 12533:1999

FFC-88-C

UL 94

4 TEST APPARATUS AND CONDITIONS

This section establishes the basic design requirements for the various apparatus types used to test casters and wheels. Refer to sections 5 – 7 for the testing procedures and acceptance criteria for specific types of casters as follows:

Section 5 – Furniture Chair Casters

Section 6 – Industrial Casters

Section 7 – Institutional and Medical Equipment Casters

Note that all recording instruments, weights, loads, gages, timing devices and measuring devices shall be calibrated on a regular basis.

Note that all tests shall be performed within an ambient temperature range of 65-75°F (18-24°C) unless otherwise specified within a test Section.

4.1 Sequence of Tests for All Casters

Initial Wheel Play Test (4.2)

Initial Swivel Play Test (4.3)

Rollability Test (4.4)

Conductivity Test (4.5)

Initial Wheel Brake Efficiency Test (4.6)

Initial Swivel Lock Efficiency Test (4.6)

Braking and/or Locking Device Fatigue Test (4.7)

Dynamic Test (4.8)

Static Test (4.9)

Final Wheel Brake Efficiency Test (4.6)

Final Swivel Lock Efficiency Test (4.7)

Final Wheel Play Test (4.2)

Final Swivel Play Test (4.3)

Side Load Test (4.10)

Caster – Vertical Impact Test (4.11)

Wheels – Vertical Impact Test (4.11)

4.2 Wheel Play Test

This section establishes the basic requirements for an apparatus to measure wheel play at the beginning of the test sequence and at the end of the test sequence.

- 4.2.1 The test fixture shall be so constructed as to rigidly fix the caster assembly in a horizontal or vertical position.
- 4.2.2 A suitable measuring device accurate to 0.001" (0.0254 mm), shall be clamped to the fixture to record the amount of movement as the wheel is tilted from side to side.
- 4.2.3 The measurement shall be taken at the farthest point from and parallel to the axle (Refer to Figure 55.)

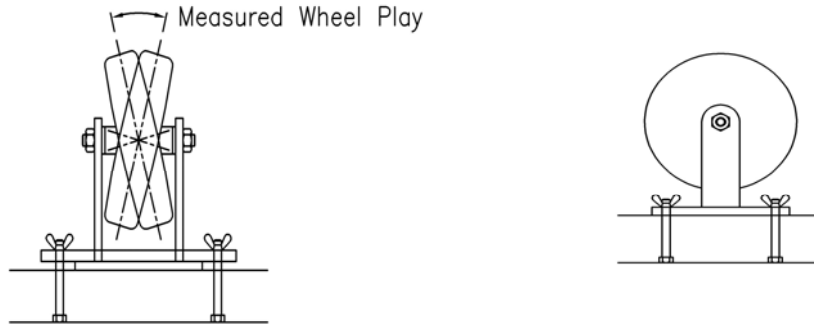

Figure 55: Wheel Play Test Apparatus

4.3 Swivel Play Test

This section establishes the basic requirements for an apparatus to measure the swivel play at the beginning of the test sequence and at the end of the test sequence.

Swivel play is the amount of vertical play between the mounting attachment and the caster housing/rig. This measurement is converted to degrees.

- 4.3.1 The apparatus consists of an amplifying bar at least 8" (20 cm) long, an indicator accurate to 0.001" (0.0254 mm) and a securing device.
- 4.3.2 The caster is to be secured such that the mounting attachment is free rotating and horizontal.
- 4.3.3 Refer to Figure 56 as an example of the testing position and apparatus.

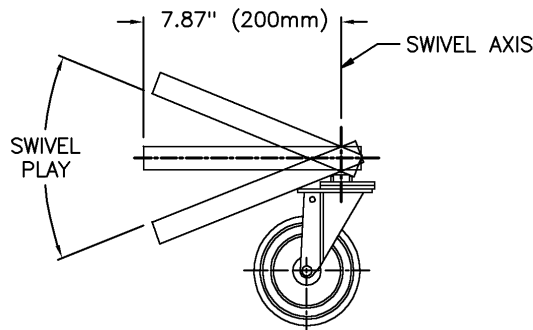

Figure 56: Swivel Play Test Apparatus

4.4 Rollability Test

This section establishes the basic requirements for an apparatus to measure the rolling and swiveling performance of a caster at its load capacity.

- 4.4.1 The apparatus for rolling and swiveling forces shall be constructed to accommodate one or more swivel casters.
- 4.4.2 The test machine shall be constructed so that the test plane is horizontal and the calibrated force gage shall be applied to the caster parallel to the test plane and positioned as close to the wheel axis as possible.
- 4.4.3 The test surface should be smooth steel and parallel to the mounting plane of the caster.
- 4.4.4 The test machine shall be rigid enough to prevent any deflection that would affect the accuracy of the test.
- 4.4.5 A weight equal to the load capacity is applied through dead weights or hydraulic, or pneumatic means.
- 4.4.6 The coefficient of friction between wheel type and surface should be discounted (Refer to Figure 57).

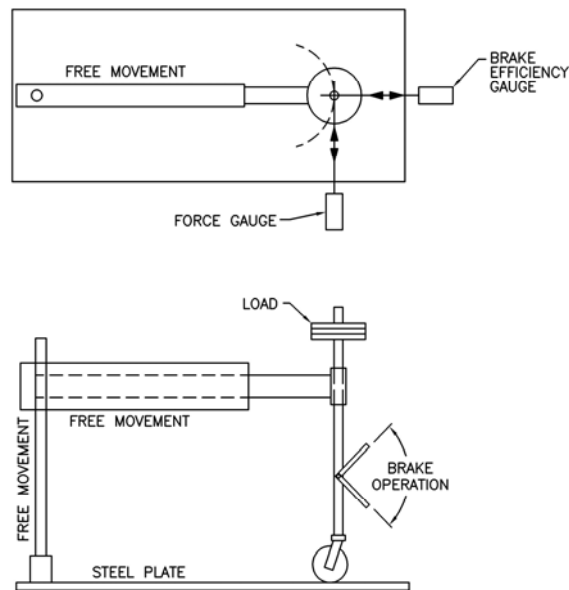

Figure 57: Rollability Test Apparatus

Note: The apparatus shown is for illustration only.

4.5 Conductivity Test

This section establishes basic requirements of the testing apparatus used to conduct electrostatic measurements of wheels and casters.

This test measures the surface electrical resistance of a wheel and/or caster.

- 4.5.1** The wheel shall be tested while supporting a load of 25% of its load capacity. The caster to be tested shall be rolled onto a clean, dry, flat metal plate. The metal plate and the mounting plane (2.5.8) of the caster shall form the electrodes for the test. The resistance between electrodes shall be measured by any resistance measuring apparatus of a suitable range.

4.6 Wheel Brake and Swivel Lock Efficiency Test

This section establishes the basic requirements for the apparatus used to determine the performance of the wheel-braking and swivel-lock devices.

This test apparatus applies to casters supplied with a device that locks the rotational movement of the wheel, the swivel, or both the wheel and the swivel.

- 4.6.1** The apparatus shall provide fixtures that allow the caster to be mounted by its normal attachments.
- 4.6.2** The apparatus shall provide a wheel contact surface that is flat and smooth.
- 4.6.3** The apparatus shall provide a force equal to the load capacity of the caster perpendicular to the mounting plane and the test surface.
- 4.6.4** The apparatus shall provide the capability to attach a calibrated force gage to the caster parallel to the test surface. The maximum range of the force gage must exceed 25% of the load capacity of the caster and have 1 lbf (4.5 N), or smaller increments.
- 4.6.5** The test apparatus must be constructed so that the horizontal force may be applied at 90° increments and the friction inherent in the machine is discounted (Refer to Figure 58).

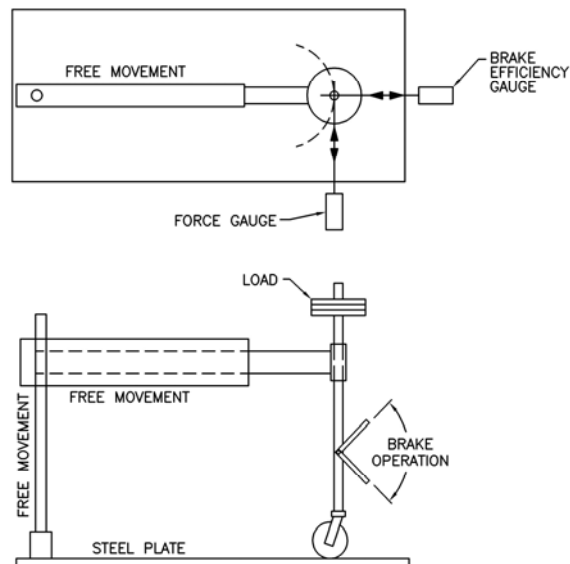

Figure 58: Wheel Brake and Swivel Lock Efficiency Test Apparatus

4.7 Braking and/or Locking Fatigue Test

This section establishes the basic design requirements for the apparatus used to fatigue test braking and/or locking mechanisms for casters.

This test apparatus applies to casters supplied with a device that locks the rotational movement of the wheel, the swivel, or both the wheel and the swivel.

- 4.7.1 The apparatus shall provide fixtures that allow the caster to be mounted by its normal attachments.
- 4.7.2 The apparatus must cycle the braking or locking device through its entire range of motion.
- 4.7.3 Test apparatus will allow continuous cycling from the braking to the non-braking position (Refer to Figure 59).

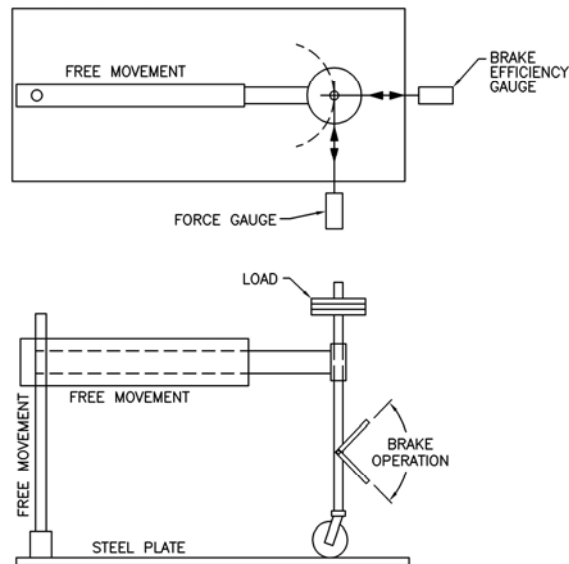

Figure 59: Braking and/or Locking Fatigue Test Apparatus

Note: The apparatus shown is for illustration only.

4.8 Dynamic Test

This section establishes the basic requirements of the apparatus to conduct dynamic testing. **No artificial cooling shall be used on the caster or wheel.**

This test apparatus established the maximum dynamic load that can be carried by the caster.

- 4.8.1 The apparatus shall provide fixtures that allow the caster to be mounted by its normal attachments.
- 4.8.2 The test surface shall be smooth steel and parallel to the mounting plane (2.5.8) of the caster.

- 4.8.3 The apparatus shall provide a force equal to the dynamic load capacity of the caster perpendicular to the mounting plane and the test surface. ICWM recommends the use of dead weight for dynamic testing. If pneumatic or hydraulic loads are applied, then a normalizing factor must be used.
- 4.8.4 The test machine should be rigid enough to prevent any deflection that would affect the accuracy of the test.
- 4.8.5 Refer to the appropriate dynamic test for surface speed. The minimum obstacle crossing speed shall be equal to the surface speed.
- 4.8.6 The track configuration is open. The track can be linear or circular, horizontal or vertical.
- 4.8.7 A device that records cycles and/or time should be used to measure test time.
- 4.8.8 Refer to section(s) 6.8.1 for obstacle size and orientation.

4.9 Static Test

This section establishes the basic requirements of the apparatus used to conduct static loading.

This test apparatus establishes the maximum static load that can be carried and meet the minimum standards set forth, with no functional impairment to the caster.

- 4.9.1 The apparatus shall provide fixtures that allow the caster to be mounted by its normal attachments.
- 4.9.2 The test surface shall be smooth steel and parallel to the mounting plane (2.5.8) of the caster.
- 4.9.3 The apparatus shall provide a force equal to four (4) times the static load capacity of the caster applied perpendicular to the mounting plane and the test surface.
- 4.9.4 The test machine should be rigid enough to prevent any deflection that would affect the accuracy of the test.

4.10 Side Load Test

This section establishes the basic requirements for the apparatus used to conduct a side-load test on a rigid caster.

The side load is the maximum transverse force that a rigid caster can withstand before permanent deformation is encountered.

- 4.10.1 The test apparatus shall be capable of applying a compressive load parallel to the wheel axis and at the axle.
- 4.10.2 The mounting fixture shall be sufficiently rigid so that its deflection, due to the load applied to the caster, can be ignored.
- 4.10.3 The load can be applied by means of dead weights or hydraulic, or pneumatic means such that a successive increase in load can be applied up to the load capacity of the caster.

- 4.10.4** A recording instrument with a range up to 1" (2.5 cm) travel, and accurate to 0.001" (0.0254 mm), shall be used in conjunction with compressive force.

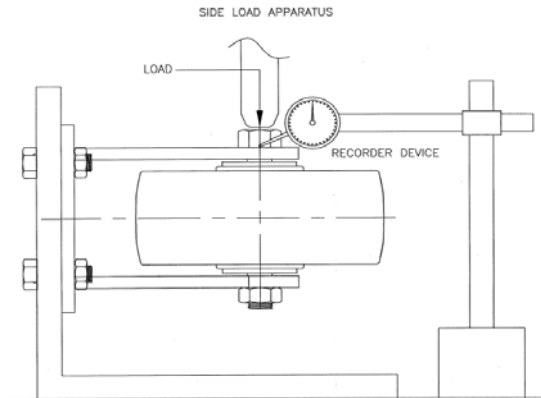

Figure 60: Side Load Test Apparatus

4.11 Caster/Wheel – Vertical Impact Test

This section establishes the basic test apparatus used to conduct a vertical impact test on casters and wheels.

This test measures the impact resistance of caster wheels.

- 4.11.1** A device that transmits force, usually measured in lbs. (N), to the test caster/wheel from a free-falling weight (Refer to Figure 61 for orientation).
- 4.11.2** The apparatus can be any design that will allow a guided free-falling weight to drop on the supported caster/wheel.
- 4.11.3** A measuring device to determine free fall distance is to be mounted parallel to the free fall weight path (Refer to Figure 61 for orientation).
- 4.11.4** The mounting fixture must be rigid enough to prevent deflection during the impact test.

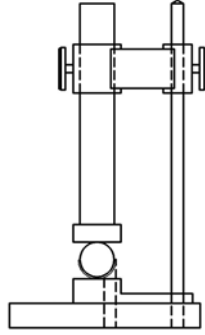

Figure 61: Vertical Impact Test Apparatus

FURNITURE CHAIR CASTERS – TEST PROCEDURE AND ACCEPTANCE CRITERIA

This section applies to casters that will normally be used in home/office environments for chair applications only. It covers categories, dimensions, and testing procedures.

5.1 Categories

Office furniture casters are classified into 5 categories based on wheel diameter:

1. Single wheel 2" (5 cm)
2. Single wheel 2 ½" (6.25 cm)
3. Single wheel 3" (7.5 cm)
4. Dual wheel 2" (5 cm)
5. Dual wheel 2 ½" (6.25 cm)

5.2 Dimensions

Minimum dimensions for office furniture casters are as follows:

<u>Wheel Diameter</u>	<u>Dimension</u>
Min. Wheel (Single wheel)	2" (5 cm) diameter
Max. Wheel (Single wheel)	3" (7.5 cm) diameter
Min. Wheel (Dual wheel)	2" (5 cm) diameter
Max. Wheel (Dual wheel)	2 ½" (6.25 cm) diameter

5.3 Testing – General Requirements

The manufacturer shall be free to choose the design, raw materials, surface treatments, embellishments, and methods of manufacture used so long as the requirements of this standard are complied with.

- 5.3.1 All tests must be conducted with the same caster.
- 5.3.2 No caster or part of a caster shall become detached during the test. Each caster shall be capable of carrying out its normal function at the end of the test program.

5.4 Test Procedures and Acceptance Criteria

- 5.4.1 Must comply with American National Standards Institute (ANSI) and Business & Institutional Furniture Manufacturers Association (BIFMA) Standards in that "no structural breakage or loss of serviceability" is allowed. The acceptance criteria per BIFMA 5.1 – 2000 specification state, "Structural breakage or loss of serviceability shall constitute failure. No failure shall be allowed that in any way would cause personal injury to the occupant." Dynamic test shall be performed per ANSI/BIFMA X5.1 – 2002. The following test procedures shall be used:

- 5.4.1.1** Attach the chair base with casters to a cycling device as shown in Figure 62. If the casters have hard treads (greater than or equal to 90 Shore A), conduct the test with a smooth, hard surface on the test platform. If casters have soft treads, mount three obstacles on the test platform in accordance with the layout (Refer to Figure 62).
- 5.4.1.2** Apply a load of 300 pounds (136 kg), including the hopper (the unit that holds the weight), to the chair base. The base and casters shall be free to rotate and swivel.
- 5.4.1.3** Adjust the length of stroke of the cycling device to ensure 30" (75 cm) of travel. On tests for soft tread casters, this travel shall be oriented with the obstacles (Refer to Figure 62).
- 5.4.1.4** Operate the machine at a rate of 9 ± 1 cycles per minute. One cycle shall consist of a forward and a backward stroke of the machine. If the casters have hard treads, cycle the device for 100,000 cycles. If the casters have hard soft treads, cycle the device for 36,000 cycles. Findings shall be recorded in accordance with the acceptance level in ANSI/BIFMA X5.1 – 2002 (Refer to Figure 62).

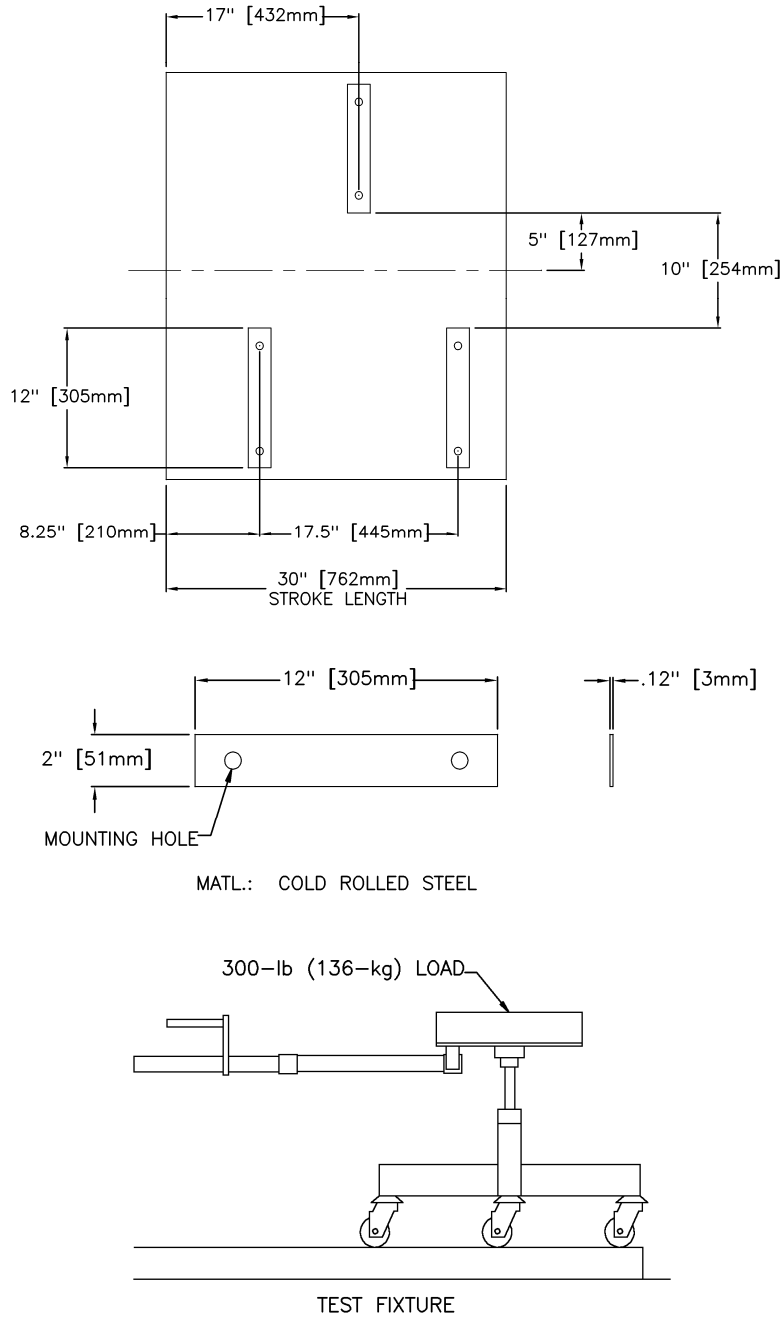

Figure 62: Dynamic Test Apparatus for Furniture Chair Casters

5.4.2 Vertical Impact Test

A caster is rigidly mounted by its normal attachment to a test fixture such that a free-falling weight is allowed to strike the tread of the wheel(s). In the case of a twin wheel caster, both wheels should be struck simultaneously.

Evaluate minimum standards for vertical impact strength, in-lbs. or N-m.

The caster shall have no loss of function or serviceability and show no visible signs of fracture.

Table 1
Drop Test

<u>Diameter</u>	<u>Minimum Impact (in-lb)</u>
Single wheel 2" (5 cm) Soft Tread	180
Single wheel 2" (5 cm) Hard Tread	90
Single wheel 2 ½" (6.25 cm) Soft Tread	180
Single wheel 2 ½" (6.25 cm) Hard Tread	110
Single wheel 3" (7.5 cm) Soft Tread	210
Single wheel 3" (7.5 cm) Hard Tread	150
Dual wheel 2" (5 cm) Soft and Hard Tread	180
Dual wheel 2 ½" (6.25 cm) Soft and Hard Tread	180

5.4.3 Caster Retention

At the conclusion of durability cycling, apply a 5 lbf (22-N) force to each caster in line with the caster stem centerline. The caster shall not separate from the base as a result of the application of a 5-lbs. (2.3 kgs) load. Minimum pull out force shall be 5 lbf. (22-N) after the caster has completed dynamic requirements in 5.4.1.

5.4.4 Conductivity Test

The caster shall be tested while supporting a load of 25% of its load capacity. The caster to be tested shall be rolled onto a clean, dry, flat metal plate. The metal plate and the mounting plane (2.5.8) of the caster shall form the electrodes for the test. Any resistance measuring apparatus of a suitable range shall measure the resistance between electrodes. The wheel shall be rotated and measurements taken at 5 separate points of contact; average these values.

Minimum standards of 250,000 ohms on average of 5 readings/wheel (Refer to FFC-88-C).

Average conductivity shall be less than 250,000 ohms and the maximum individual conductivity shall be less than 1,000,000 ohms. All conductive wheels may have a colored dot permanently affixed to the wheel surface, excluding tread, to indicate conductivity, at the manufacturer's discretion

This test does not guarantee that the level of conductivity indicated during the testing will be achieved in application. The manufacturer is not responsible for any change, either loss or gain in conductivity due to, but not limited to, accumulation of dirt, wax, or foreign materials on the wheel.

5.5 Conformity

The manufacturer declares on request by a Certificate of Compliance that the casters conform to the requirements as stated in this document.

5 INDUSTRIAL CASTERS – TEST PROCEDURES AND ACCEPTANCE CRITERIA

6.1 Wheel Play Test

The objective of this test is to determine the initial wheel play (at the beginning of the test sequence) and the final wheel play (at the end of the test sequence).

6.1.1 Test Procedure

- 6.1.1.1 The measurements shall be taken with the wheel, bearing, and axle assembled in the fork.
- 6.1.1.2 The fork (2.5.7) of the caster shall be rigidly fixed in a vertical position to ensure that the fork width is maintained and movement of wheel is not impaired.
- 6.1.1.3 The wheel shall then be manually tilted to one side then the opposite side, and the total movement measured (Refer to Figure 63).
- 6.1.1.4 The wheel play shall not include any side movement of the wheel on the axle.
- 6.1.1.5 The wheel play value shall be expressed in degrees.

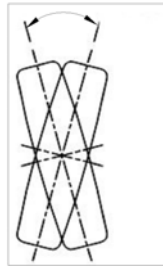

Figure 63: Wheel Play

6.1.2 Acceptance Criteria

- 6.1.2.1 The measured initial wheel play shall not exceed 3.5°.
- 6.1.2.2 The measured final wheel play shall not exceed 6.5°.

6.2 Swivel Play Test

The objective of this test is to determine the initial swivel play (at the beginning of test sequence) and the final swivel play (at the end of the test sequence).

6.2.1 Test Procedure

- 6.2.1.1 The measurements shall be taken with the wheel, bearing, and axle assembled in the fork (2.5.7).

- 6.2.1.2** The fork (2.5.7) of the caster shall be rigidly fixed in a vertical position to ensure that the fork width is maintained and movement of swivel is not impaired.
- 6.2.1.3** Place alignment marks on the fixed and swiveling parts of the caster.
- 6.2.1.4** The amplifying bar shall be rigidly attached to the mounting plane (2.5.8), pass through the swivel axis, and for top plate (2.5.9) casters, be parallel to the direction of travel.
- 6.2.1.5** Measure swivel play by moving the amplifying bar in a vertical plane first to the limit of swivel play in one direction and then to the limit of swivel play in the opposite direction (Refer to Figure 64).
- 6.2.1.6** Record the vertical distance between swivel play extremes at a point on the amplifying bar at least 8" (20 cm) from the axis and convert to an angle in degrees.
- 6.2.1.7** Make two measurements each at 90° of swivel rotation from the other. The larger of the two values shall be taken.

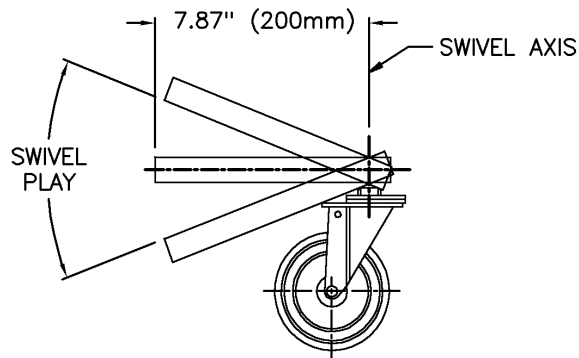

Figure 64: Swivel Play

6.2.2 Acceptance Criteria

- 6.2.2.1** The measured initial swivel play shall not exceed 3° except for light duty.
- 6.2.2.2** The measured final swivel play shall not exceed 6° except for light duty.
- 6.2.2.3** The measured initial swivel play for light duty, as defined by the manufacturer, casters shall not exceed 6°.
- 6.2.2.4** the measured final swivel play for light duty, a defined by the manufacturer, casters shall not exceed 12°.

6.3 Rollability Test

The objective of this test is to evaluate the rolling and swiveling performance of a caster at the load capacity. The swiveling portion of this test does not apply to rigid casters.

6.3.1 Test Procedure

- 6.3.1.1** Secure the caster(s) to the test fixture.

- 6.3.1.2 Apply the load to the test fixture so it is centered over and supported by the caster(s).
 - 6.3.1.3 Attach a measuring device to the test fixture to indicate the force required to move the caster(s).
 - 6.3.1.4 Orient the caster(s) so that the wheel(s) are aligned with the direction of travel.
 - 6.3.1.5 Apply a gradual force to the fixture in line with the direction of travel while watching the wheel(s) of the caster(s) for rotational movement. Record the peak force (Start-rolling force) required to begin rotation of the caster(s) wheel(s).
 - 6.3.1.6 Continue applying force until the caster(s) rolls freely and the measured reading stabilizes. Read the measuring device and record the force (Keep-rolling force) required to maintain the movement of the caster(s).
 - 6.3.1.7 Repeat "Test Procedure" steps 6.3.1.3 through 6.3.1.6 for a minimum of three trials, averaging the results.
 - 6.3.1.8 Orient the caster(s) so that the wheel(s) are perpendicular to the direction of travel.
 - 6.3.1.9 Apply gradual force to the fixture in line with the direction of travel. Record the peak force (Swivel force) as the caster(s) swivels to align with the direction of travel.
 - 6.3.1.10 Repeat "Test Procedure" steps 6.3.1.8 and 6.3.1.9 for a minimum of three trials, averaging the results.
- 6.3.2 Acceptance Criteria**
- 6.3.2.1 Caster must roll and swivel smoothly.
 - 6.3.2.2 Actual values for the rolling and swivel forces are application specific and can be determined by the customer and the caster supplier.

6.4 Conductivity Test

The objective of this test is to establish procedures for testing and identifying electrostatically conductive wheels and casters and to establish the maximum electrical resistance of a wheel and/or caster.

6.4.1 Test Procedure

- 6.4.1.1 The tread surfaces shall be cleaned and dried by any method that removes wax and dirt, but does not alter the tread surface.
- 6.4.1.2 The test room shall have a mean temperature of 68-72°F (20-22°C) and a relative humidity of less than 80%.
- 6.4.1.3 The caster being tested must be maintained under these conditions for a minimum of 24 hours prior to the test.
- 6.4.1.4 The wheel shall be tested while supporting a load of 25% of its load capacity. The caster to be tested shall be rolled onto a clean, dry, flat metal plate. The metal plate and the mounting plane (2.5.8) of the caster shall form the electrodes

for the test. The resistance between electrodes shall be measured by any resistance measuring apparatus of a suitable range. The wheel shall be rotated and measurements taken at 5 separate points of contact, averaging the values.

6.4.2 Acceptance Criteria

Electrical resistance categories are defined below:

6.4.2.1 Conductive less than 10^5 ohms. All conductive wheels should have a colored dot permanently affixed to the wheel surface, excluding tread, to indicate conductivity, at the manufacturer's discretion.

6.4.2.2 Static dissipative less than 10^7 ohms and more than 10^5 ohms.

6.4.2.3 Insulation shall be greater than 10^7 ohms.

6.4.3 This test does not guarantee that the level of conductivity indicated during the testing will be achieved in application. The manufacturer is not responsible for any change, either loss or gain in conductivity due to, but not limited to, accumulation of dirt, wax, or foreign materials on the wheel.

6.5 Wheel Brake Efficiency Test

The objective of this test is to determine the performance of a wheel-braking device.

The brake designs will be tested per the following criteria: tread compression (a braking device that applies a friction force to the tread); hub compression (a braking device that applies a friction force to the hub); positive locking (a braking device that incorporates interlocking features).

6.5.1 Test Procedure

6.5.1.1 Place the caster on a horizontal surface free from visible dirt.

6.5.1.2 Apply a load equal to the load capacity of the caster to the mounting plane (2.5.8).

6.5.1.3 Perform the Rollability Test. Note the start-rolling force.

6.5.1.4 Engage the brake.

6.5.1.5 Gradually apply the horizontal force (Refer to Table 2) plus the start-rolling force from the Rollability Test in line with the running direction of the wheel.

6.5.1.6 Maintain the horizontal force for 10 seconds. If during application of the horizontal force the wheel slides, change the surface to a material with a higher coefficient of friction and repeat the test.

6.5.1.7 Repeat Test Procedure steps 6.5.1.4, 6.5.1.5, and 6.5.1.6 applying the horizontal force in the opposite direction. With the brake engaged and applying the horizontal force, the wheel must not roll.

6.5.2 Acceptance Criteria

Table 2
Minimum Brake Holding Force

<u>Brake Design</u>	<u>% of Load Capacity</u>
Tread compression	7%
Hub compression	4%
Positive locking	20%

Note: Data for Table 2 based on polyurethane wheels with a durometer of 90 Shore A.
(Consult manufacturer on data on other wheel materials).

6.6 Braking and/or Locking Device Fatigue Test

This test is to determine if there is any wear and/or permanent deformation that would adversely affect the performance of a braking and/or locking device.

This test is not applicable to braking and/or locking devices based on a threaded mechanism.

6.6.1 Test Procedure

6.6.1.1 Install the brake and/or locking device into an apparatus that cycles the actuating mechanism through a full "on" and "off" cycle.

6.6.1.2 Brake holding power shall be checked before and after the fatigue test (refer to Wheel Brake Efficiency Test).

6.6.2 Acceptance Criteria

5,000 locking actions performed with no permanent deformation occurring that would adversely affect the performance of the locking device.

6.7 Static Test

The objective of this test is to determine a minimum factor of safety and to determine the load that the caster can support without causing permanent deformation that would impair the function of the caster.

6.7.1 Test Procedure

6.8.1.1 Apply a compressive load equal to 4 times the load capacity of the individual caster through the mounting plane (2.5.8) for a period of 1 minute.

6.8.1.2 Examine the caster for damage or permanent deformation.

6.7.2 Acceptance Criteria

The swivel and wheel bearings shall rotate freely and the parts shall be free from defects, which would impair caster function.

6.8 Dynamic Test

6.8.1 Dynamic Test – Industrial Casters at or under 2.5 mph (4 kph)

The objective of this test is to establish operational load capacity for industrial casters at or under 2.5 mph (4 kph) and to establish the maximum load that can be carried during operation and pass the following test procedure with no functional impairment to the caster.

6.8.1.1 Test Procedure

- 6.8.1.1.1** The test running speed will be 2.0 mph minimum (3.2 kph).
- 6.8.1.1.2** The obstacle orientation to caster travel for circular track, vertical position shall be alternately; perpendicular, 45° to the right, and 45° to the left.
- 6.8.1.1.3** The obstacle orientation to caster travel for linear track and circular track (horizontal position) shall be 90°.
- 6.8.1.1.4** The obstacle shall be 2" (5 cm) wide steel with a chamfer 45° by one-half the obstacle height on the running edges.
- 6.8.1.1.5** The allowable track configurations are linear track, circular track (horizontal position), and circular track (vertical position).

Table 3

**Criteria for Dynamic Testing
 Industrial Caster at or under 2.5 mph (4 kph)**

Wheel Diameter (in)	0 – 3	>3 – 12	>12
Wheel Diameter (cm)	0 – 7.5	>7.5 – 30	>30
Minimum Run Time (min)	2	2	2
Maximum Rest Time (min)	6	4	2
Run Distance (miles)	4	4	4
Run Distance (km)	6.4	6.4	6.4
Height of Obstacle (in)	1/16	1/8	3/16
Height of Obstacle (mm)	1.59	3.18	4.76
Number of Obstacles (Plate)	5000	5000	7500
Number of Obstacles (Stem)	500	500	—

6.8.1.2 Acceptance Criteria

There shall be no functional impairment of the caster.

6.8.2 Dynamic Test – Industrial Caster over 2.5 mph (4 kph)

The objective of this test is to establish operational load capacity for industrial casters over 2.5 (4 kph) mph and to establish the maximum load that can be carried and pass the following test procedure with no functional impairment to the caster.

6.8.2.1 Test Procedure

6.8.2.1.1 The running speed and distance between obstacles shall be one of the three following configurations based on the caster application.

Running Speeds

3.75 mph (6 kph)	6.25 mph (10 kph)	10.00 mph (16 kph)
---------------------	----------------------	-----------------------

6.8.2.1.2 The obstacle shall be 2" (5 cm) wide steel with a chamfer 45° by one-half the obstacle height on the running edges.

6.8.2.1.3 The obstacle orientation to caster travel for linear tracks and circular tracks shall be 90°.

6.8.2.1.4 The obstacle cross section shall be rectangular with a chamfer 45° by one-half the obstacle height on the running edges.

6.8.2.1.5 The allowable track configurations are linear and circular.

Table 4

**Criteria for Dynamic Testing
 Industrial Caster over 2.5 mph (4 kph)**

Wheel Diameter (in)	0 – 3	>3 – 12	>12
Wheel Diameter (cm)	0 – 7.5	>7.5 – 30	>30
Minimum Run Time (min)	2	2	2
Maximum Rest Time (min)	6	4	2
Run Distance (miles)	4	4	4
Run Distance (km)	6.4	6.4	6.4
Height of Obstacle (in)	1/16	1/8	3/16
Height of Obstacle (mm)	1.59	3.18	4.76
Number of Obstacles (Plate)	500	5000	7500

6.8.2.2 Acceptance Criteria

There shall be no functional impairment to the caster.

6.9 Side Load Test

This test is to determine the suitability of the rig strength per the following Test Procedure and Acceptance Criteria.

This Side Load Test applies to rigid casters only.

6.9.1 Test Procedure

6.9.1.1 Attach the caster to a suitable test fixture.

6.9.1.2 Apply a force equal to the load capacity at and parallel to the axle.

6.9.1.3 Measure and record the movement of the axle, relative to the mounting plane (2.5.8), at maximum load. Measure the permanent deflection after the load is removed.

6.9.1.4 Use an instrument sensitive to 0.001" (0.0254 mm) or less.

6.9.1.5 The test fixture shall have sufficient rigidity so that its deflection, due to the load applied to the caster, can be ignored.

6.9.2 Acceptance Criteria

The maximum movement of the axle relative to the mounting plane (2.5.8) shall not exceed the value of .070 times the nominal wheel diameter.

The permanent deflection of the axle to the application and removal of the load shall not exceed the value of .030 times the nominal wheel diameter.

6.10 Casters – Vertical Impact Test

The objective of this test is to determine the minimum impact strength of the caster per the following Test Procedure and Acceptance Criteria.

This Vertical Impact Test applies to rigid and swivel casters.

6.10.1 Test Procedure

6.10.1.1 A caster is rigidly mounted wheel up in a test fixture on a solid surface so that a free-falling weight can impact the tread perpendicular to the axis of the wheel.

6.10.1.2 The minimum vertical impact force shall be equivalent to the load capacity of the caster dropped 2" (5 cm).

6.10.1.3 In the case of multiple wheel casters, all wheels shall be impacted simultaneously.

6.10.2 Acceptance Criteria

There shall be no functional impairment of the caster.

Note: In the case of multiple wheel casters, all wheels shall be impacted simultaneously.

6.11 Wheels – Vertical Impact Test

The objective of this test is to determine the minimum impact strength of the wheel per the following Test Procedure and Acceptance Criteria.

This Vertical Impact Test applies to wheels.

6.11.1 Test Procedure

- 6.11.1.1** The wheel shall be tested while suspended on a special test axle, as defined below.
- 6.11.1.2** The axle diameter shall be 0.005" to 0.015" (0.13 mm to 0.38 mm) smaller than the diameter of the bore.
- 6.11.1.3** The axle shall be made from drill rod, or equivalent material, and hardened to a minimum of 40 Rockwell C.
- 6.11.1.4** The axle shall be straight, solid, and supported not more than 0.031" (0.8 mm) from the hub.
- 6.11.1.5** The minimum vertical impact force shall be equivalent to the load capacity of the wheel dropped 2" (5 cm).
- 6.11.1.6** The wheel will be dismounted and examined for defects. Any failure will cause the wheel to be rejected.

6.11.2 Acceptance Criteria

There shall be no functional impairment of the wheel.

6 INSTITUTIONAL AND MEDICAL EQUIPMENT CASTERS – TEST PROCEDURES AND ACCEPTANCE CRITERIA

7.1 Wheel Play Test

The objective of this test is to determine the initial wheel play (at the beginning of the test sequence) and the final wheel play (at the end of the test sequence).

7.1.1 Test Procedure

- 7.1.1.1 The measurements shall be taken with the wheel, bearing, and axle assembled in the fork.
- 7.1.1.2 The fork (2.5.7) of the caster shall be rigidly fixed to ensure that the fork width is maintained and the movement of the wheel is not impaired.
- 7.1.1.3 The wheel shall then be manually tilted to one side then the opposite side, and the total movement measured (refer to Figure 65).
- 7.1.1.4 The wheel play shall not include any side movement of the wheel on the axle.
- 7.1.1.5 The wheel play value shall be expressed in degrees.

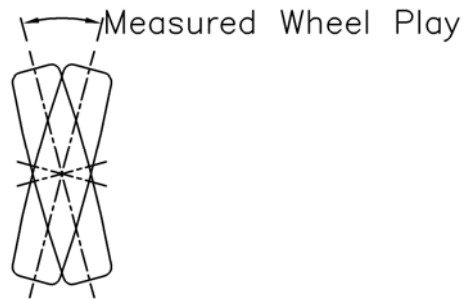

Figure 65: Wheel Play

7.1.2 Acceptance Criteria

- 7.1.2.1 The measured initial wheel play shall not exceed 3.5°.
- 7.1.2.2 The measured final wheel play shall not exceed 6.5°.

7.2 Swivel Play Test

The objective of this test is to determine the initial swivel play (at the beginning of the test sequence) and the final swivel play (at the end of the test sequence).

7.2.1 Test Procedure

- 7.2.1.1 The measurements shall be taken with the wheel, bearing, and axle assembled in the fork.
- 7.2.1.2 The fork (2.5.7) of the caster shall be rigidly fixed in a vertical position to ensure that the fork width is maintained and movement of swivel is not impaired.

- 7.2.1.3** Place alignment marks on the fixed and swiveling parts of the caster.
- 7.2.1.4** The amplifying bar shall be rigidly attached to the mounting plane (2.5.8), pass through the swivel axis, and for top plate casters, be parallel to the direction of travel.
- 7.2.1.5** Measure swivel play by moving the amplifying bar in a vertical plane first to the limit of swivel play in one direction and then to the limit of swivel play in the opposite direction (refer to Figure 66).
- 7.2.1.6** Record the vertical distance between swivel play extremes at a point on the amplifying bar at least 8" (20 cm) from the axis and convert to an angle in degrees.
- 7.2.1.7** Make two measurements each at 90° of swivel rotation from the other. The larger of the two values shall be taken.

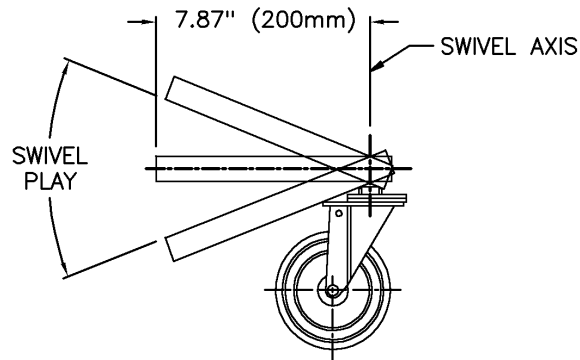

Figure 66: Swivel Play

7.2.2 Acceptance Criteria

- 7.2.2.1** The measured initial swivel play shall not exceed 3° except for light duty, as defined by the manufacturer, casters.
- 7.2.2.2** The measured final swivel play shall not exceed 6° except for light duty, as defined by the manufacturer, casters.
- 7.2.2.3** The measured initial swivel play for light duty, as defined by the manufacturer, casters shall not exceed 6°.
- 7.2.2.4** The measured final swivel play for light duty, as defined by the manufacturer, casters shall not exceed 12°.

7.3 Rollability Test

The objective of this test is to evaluate the rolling and swiveling performance of a caster at the load capacity. The swiveling portion of this test does not apply to rigid casters.

7.3.1 Test Procedure

- 7.3.1.1** Secure the caster(s) to the test fixture.
- 7.3.1.2** Apply the load capacity to the test fixture so it is centered over and supported by the caster(s).
- 7.3.1.3** Attach a measuring device to the test fixture to indicate the force required to move the caster(s).
- 7.3.1.4** Orient the caster(s) so that the wheel(s) are aligned with the direction of travel.
- 7.3.1.5** Apply a gradual force to the fixture in line with the direction of travel while watching the wheel(s) of the caster(s) for rotational movement. Record the peak force (Start-rolling force) required to begin rotation of the caster(s) wheel(s).
- 7.3.1.6** Continue applying force until the caster(s) rolls freely and the measured reading stabilizes. Read the measuring device and record the force (Keep-rolling force) required to maintain the movement of the caster(s).
- 7.3.1.7** Repeat Test Procedure steps 7.3.1.3 through 7.3.1.6 for a minimum of three trials; average the results.
- 7.3.1.8** Orient the caster(s) so that the wheel(s) are perpendicular to the direction of travel.
- 7.3.1.9** Apply a gradual force to the fixture in line with the direction of travel. Record the peak force (Swivel force) as the caster(s) swivels to align with the direction of travel.
- 7.3.1.10** Repeat Test Procedure steps 7.3.1.8 and 7.3.1.9 for a minimum of three trials; average the results.

7.3.2 Acceptance Criteria

- 7.3.2.1** Caster(s) must roll and swivel smoothly.
- 7.3.2.2** Actual values for the rolling and swivel forces are application specific and can be determined by the customer and the caster supplier.

7.4 Wheel Brake Efficiency Test

The objective of this test is to determine the performance of the wheel braking device.

The brake designs will be tested per the following criteria: tread compression (a braking device that applies a friction force to the tread); hub compression (a braking device that applies a friction force to the hub); positive locking (a braking device that incorporates interlocking features).

7.4.1 Test Procedure

- 7.4.1.1** Place the caster on a horizontal surface free from visible dirt.

- 7.4.1.2 Apply a load equal to the load capacity of the caster to the mounting plane (2.5.8).
- 7.4.1.3 Perform the Rollability Test. Note the start-rolling force.
- 7.4.1.4 Engage the brake.
- 7.4.1.5 Gradually apply the horizontal force (refer to Table 5) plus the start-rolling force from the rollability test in line with the running direction of the wheel.
- 7.4.1.6 Maintain the horizontal force for 10 seconds. If during application of the horizontal force the wheel slides, change the surface to a material with a higher coefficient of friction and repeat the test.
- 7.4.1.7 Repeat Test Procedure steps 7.4.1.4 through 7.4.1.6 applying the horizontal force in the opposite direction. With the brake engaged and applying the horizontal force, the wheel must not roll.

7.4.2 Acceptance Criteria

Table 5

Minimum Brake Holding Force

<u>Brake Design</u>	<u>% of Load Capacity</u>
Institutional	
Tread Compression	7%
Hub Compression	4%
Positive Locking	20%
Medical Bed Brake	20%

7.5 Swivel Lock Efficiency Test

The objective of this test is to determine the performance of the swivel locking device.

This test refers to swivel casters supplied with a braking or locking device acting only on its swiveling mechanism.

7.5.1 Test Procedure

- 7.5.1.1 Before and after the dynamic test (operational) the caster shall be placed on a hard, horizontal surface.
- 7.5.1.2 A test load consisting of a dead weight, or other suitable force, shall be applied perpendicular to the mounting plane (2.5.8) of the caster and equal to the load capacity.
- 7.5.1.3 A testing device shall be applied to measure a horizontal force of 20% of the load capacity at 90° to the direction of caster travel.
- 7.5.1.4 If during the application of the horizontal force the wheel slides, change the surface to a material with a high coefficient of friction and repeat the test.

7.5.2 Acceptance Criteria

The caster shall not rotate around the swivel axis, and no failures or permanent deformations shall occur that would affect the performance of the swivel lock.

7.6 Braking and/or Locking Device Fatigue Test

This test is to determine if there is any wear and/or permanent deformation that would adversely affect the performance of the braking and/or locking device.

This test is not applicable to braking and/or locking devices based on a threaded mechanism.

7.6.1 Test Procedure

7.6.1.1 Install the brake and/or locking device into an apparatus that cycles the actuating mechanism through a full "on" and "off" cycle.

7.6.1.2 Brake holding power shall be checked before and after the fatigue test.

7.6.1.2.1 Institutional: 5,000 brake actuation cycles

7.6.1.2.2 Hospital Bed: 10,000 brake actuation cycles

7.6.2 Acceptance Criteria

The test is passed if there is no wear and/or permanent deformation, which would adversely affect the performance of the caster.

7.7 Static Test

The objective of this test is to establish a minimum factor of safety, and to determine the load the caster can support without causing permanent deformation that would impair the function of the caster.

7.7.1 Test Procedure

7.7.1.1 Apply a compressive load equal to four times the load capacity of the individual caster through the mounting plane (2.5.8) for a period of one minute.

7.7.1.2 Examine the caster for damage or permanent deformation.

7.7.2 Acceptance Criteria

There shall be no functional impairment to the caster.

7.8 Dynamic Test

The objective of this test is to establish operational load capacity and the maximum load that can be carried during operation, and to pass the following test procedure with no functional impairment to the caster.

7.8.1 Test Procedure

7.8.1.1 The running speed will be 2.0 mph minimum (3.2 km/hr).

- 7.8.1.2** The obstacle height shall be: 3% of wheel diameter to a maximum height of 3/16" (4.76 mm).
- 7.8.1.3** The obstacle orientation to caster travel for circular track, vertical position shall be alternately: perpendicular, 45° to the right, and 45° to the left.
- 7.8.1.4** The obstacle orientation to caster travel for linear track and circular track (horizontal position) shall be 90°.
- 7.8.1.5** The obstacle shall be 2" (5 cm) wide steel with a chamfer 45° by one-half the obstacle height on the running edges.
- 7.8.1.6** There shall be reverse travel direction at the start of each cycle except circular track vertical position.
- 7.8.1.7** The allowable track configurations are linear track, circular track (horizontal position), and circular track (vertical position).

Table 6

**Criteria for Dynamic Testing
 Medical Equipment Casters**

Wheel Diameter (in)	0 – 3	>3 – 12	>+12
Wheel Diameter (cm)	0 – 7.5	>7.5 – 30	>+30
Minimum Run Time (min)	2	2	2
Maximum Rest Time (min)	6	4	2
Run Distance (miles)	1.5	1.5	1.5
Run Distance (km)	2.4	2.4	2.4
Height of Obstacle	Reference paragraph 7.8.1.2		
Number of Obstacles	Ten (10) times wheel diameter in millimeters.		

7.8.2 Acceptance Criteria

There shall be no functional impairment to the caster..

7.9 Conductivity Test

The objective of this test is to establish procedures for testing and identifying electro-statically conductive wheels and casters, and to establish the maximum surface electrical resistance of a wheel and/or caster.

7.9.1 Test Procedure

7.9.1.1 The tread surfaces shall be cleaned and dried by any method that removes wax and dirt, but does not alter the tread surface.

7.9.1.2 The wheel shall be tested while supporting a load of 25% of its load capacity. The caster to be tested shall be rolled onto a clean, dry, flat metal plate. The metal plate and the mounting plane (2.5.8) of the caster shall form the electrodes for the test. The resistance between electrodes shall be measured by any resistance measuring apparatus of a suitable range. The wheel shall be rotated and measurements taken at five separate points of contact; average the values.

7.9.2 Acceptance Criteria

7.9.2.1 Conductive less than 10^5 ohm. All conductive wheels may have a colored dot permanently affixed to the wheel surface, excluding tread, to indicate conductive, at the manufacturer's discretion.

7.9.2.2 Static dissipative less than 10^7 ohms and more than 10^5 ohms.

7.9.2.3 Insulation shall be greater than 10^7 ohms.

7.9.3 Disclaimer

This test does not guarantee that the level of conductivity indicated during the testing will be achieved in application. The manufacturer is not responsible for any change, either loss or gain in conductivity due to, but not limited to, accumulation of dirt, wax, or foreign materials on the wheel.

7.10 Casters – Vertical Impact Test

The objective of this test is to determine the minimum impact strength of the caster per the following Test Procedure and Acceptance Criteria. This Vertical Impact Test applies to rigid and swivel casters.

7.10.1 Test Procedure

7.10.1.1 A caster is rigidly mounted upside down in a test fixture on a solid surface so that a free-falling weight can impact the tread perpendicular to the axis of the wheel.

7.10.1.2 The minimum vertical impact force shall be equivalent to the load capacity of the caster dropped 2" (5 cm).

7.10.1.3 In the case of multiple wheel casters, all wheels shall be impacted simultaneously.

7.10.2 Acceptance Criteria

There shall be no functional impairment of the caster.

7.11 Wheels – Vertical Impact Test

The objective of this test is to determine the minimum impact strength of the wheel per the following Test Procedure and Acceptance Criteria. This Vertical Impact Test applies to wheels.

7.11.1 Test Procedure

- 7.11.1.1** The wheel shall be tested while suspended on a special test axle, as defined below.
- 7.11.1.2** The axle diameter shall be 0.005" to 0.015" (0.13 mm to 0.38 mm) smaller than the diameter of the bore.
- 7.11.1.3** The axle shall be made from drill rod, or equivalent material, and hardened to a minimum of 40 Rockwell C.
- 7.11.1.4** The axle shall be straight, solid, and supported not more than 0.031" (0.8 mm) from the hub.
- 7.11.1.5** The minimum vertical impact force shall be equivalent to the load capacity of the caster dropped 2" (5 cm).
- 7.11.1.6** The wheel will be dismounted and examined for defects.

7.11.2 Acceptance Criteria

There shall be no functional impairment of the wheel.