



FEATURES

Swivel section: Constructed of hot forged SAE 1045 steel and built to the same dimensions as popular cold forged industrial casters. The 2-1/2" diameter load race is precision machined to a mirror smooth finish.

Kingpin: 3/4" diameter, integrally forged as part of the top plate, machined concentric to the load race.

Legs: 1/4"x 2" formed steel bar and welded inside and outside to the yoke base.

Axle: 1/2" diameter axle

Lubrication: Pre-lubricated before shipping

Wheels: 4" to 8" diameter wheels with straight roller bearings, ball bearings or tapered roller bearings.

Finish: Clear zinc plating

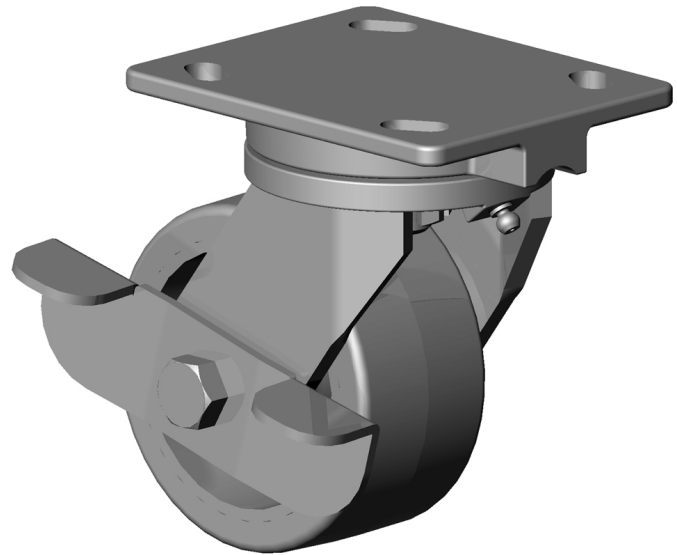

50-06201-62-1C shown with optional cam brake

BENEFITS

This heavy duty hot forged swivel caster is built for severe service. The hot forged, machined raceway with integral kingpin and steel bar formed and welded legs provides a stronger swivel with heavier section thickness. The long wearing characteristics of this caster will outperform cold forged or stamped casters in swivel applications.

APPLICATIONS

Production racks and fixtures, live skids, unitized dairy distribution carts, automated assembly lines.

OPTIONS

Brakes

Cam:	C*
Poly Cam:	P*
Tread Lock:	T
Wrap Around:	W*
Dual Side:	DS

Swivel Locks

Factory Installed:	L
Demountable:	DL
Passive:	PL

Sealed Swivel:	SSW
Sealed Wheels:	SW
Toe Guard:	TG
Heat Treated Raceways:	HT

If You Don't See It....Ask Us

In addition to the standard casters and wheels found in this catalog, Caster Concepts also provides:

- Lift truck stabilizer casters
- Turntable casters
- Press-on polyurethane wheels
- Aluminum core wheels

Other specialized solutions

CASTER CONCEPTS *Beyond Standard*

*For wheels with diameter ≥ 6 inches



CASTER CONCEPTS

50 MEDIUM HEAVY DUTY SERIES CASTERS 1500 maximum capacity LBS

50 SERIES MEDIUM DUTY CASTERS 1,500 lbs maximum capacity

WHEEL		CAPACITY				PART NUMBER			
Dia.	Width	Material	Roller Bearing	Precision Ball	OAH	Swivel Lead	Roller Bearing	Precision Ball	Wt.
4	1.50	Forged Steel	1,400	1,400	5.63	1.50	50-04101-20-1	50-04109-20-1†	7.25
4	2.00	Phenolic Resin	800		5.63	1.50	50-04201-30-1		7.50
4	2.00	Cast Iron	1,000		5.63	1.50	50-04201-10-1		7.50
4	2.00	Polyurethane	700	700	5.63	1.50	50-04201-60-1	50-04204-60-1	7.50
4	2.00	Soft Polyurethane	600	600	5.63	1.50	50-04201-66-1	50-04202-66-1	7.50
4	2.00	Envirothane	650	650	5.63	1.50	50-04201-62-1	50-04202-62-1	7.50
4	2.00	Mold on Rubber	350		5.63	1.50	50-04201-70-1		8.20
4	2.00	Softech	250	250	5.63	1.50	50-04201-72-1	50-04204-72-1*	8.00
5	2.00	Forged Steel	1,500	1,500	6.50	1.75	50-05201-20-1	50-05209-20-1†	10.20
5	2.00	Cast Iron	1,200		6.50	1.75	50-05201-10-1		9.20
5	2.00	Phenolic Resin	1,000		6.50	1.75	50-05201-30-1		8.50
5	2.00	Polyurethane	1,050	1,050	6.50	1.75	50-05201-60-1	50-05202-60-1	10.00
5	2.00	T/R Compound	850	850	6.50	1.75	50-05201-61-1	50-05202-61-1	10.00
5	2.00	Envirothane	800	800	6.50	1.75	50-05201-62-1	50-05202-62-1	7.50
5	2.00	Mold on Rubber	400		6.50	1.75	50-05201-70-1		10.00
5	2.00	Softech	275	275	6.50	1.75	50-05201-72-1	50-05204-72-1*	10.00
6	2.00	Forged Steel	1,500	1,500	7.50	2.25	50-06201-20-1	50-06209-20-1†	13.50
6	2.00	Cast Iron	1,200		7.50	2.25	50-06201-10-1		13.00
6	2.00	Phenolic Resin	1,200		7.50	2.25	50-06201-30-1		9.50
6	2.00	Polyurethane	1,200	1,200	7.50	2.25	50-06201-60-1	50-06202-60-1	12.00
6	2.00	T/R Compound	1,000	1,000	7.50	2.25	50-06201-61-1	50-06202-61-1	12.00
6	2.00	Solid Elastomer	950	950	7.50	2.25	50-06201-62-1	50-06202-62-1	12.00
6	2.00	Mold on Rubber	425		7.50	2.25	50-06201-70-1		12.00
6	2.00	Softech	450	450	7.50	2.25	50-06201-72-1	50-06204-72-1*	12.00
8	2.00	Cast Iron	1,500		10.12	2.25	50-08201-10-1		16.50
8	2.00	Phenolic Resin	1,400		10.12	2.25	50-08201-30-1		12.00
8	2.00	Polyurethane	1,500	1,500	10.12	2.25	50-08201-60-1	50-08202-60-1	14.00
8	2.00	T/R Compound	1,200	1,200	10.12	2.25	50-08201-61-1	50-08202-61-1	14.00
8	2.00	Solid Elastomer	1,300	1,300	10.12	2.25	50-08201-62-1	50-08202-62-1	14.00
8	2.00	Mold on Rubber	500		10.12	2.25	50-08201-70-1		14.00
8	2.00	Softech	600	600	10.12	2.25	50-08201-72-1	50-08204-72-1*	14.00

Capacity listed is for manual operation. For powered operations, consult factory.
 Part Numbers listed are for the swivel caster. For rigid casters, change the last digit from 1 to 2 (i.e. 50-06201-60-2)
 Estimated weight is for swivel caster. Deduct 20 percent of swivel caster weight for rigid casters.
 †This caster has tapered roller bearings.
 * This caster has annular ball bearings.
 All dimensions are in inches. All weights are in pounds.

Top Plate Size	Bolt Hole Spacing	Bolt Diameter
4.0 x 5.0	2.625 x 3.625 Slotted to 3.0 x 3.0	0.375

50 Series Cross Sectional View

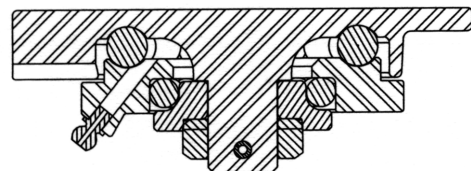

CASTER CONCEPTS WILL MODIFY ANY CASTER TO MEET CUSTOMER SPECIFICATIONS

Caster Concepts, Inc., 16000 E. Michigan Ave., Albion, MI 49224 (517) 629-8838 Facsimile (800) 800-0036 www.casterconcepts.com